

# 6A, 17V, ACOT<sup>®</sup> High-Efficiency Synchronous Step-Down Converter

## 1 General Description

The RTQ2806A is a high-performance, synchronous step-down converter that can deliver up to 6A output current with a wide input supply voltage range of 3.5V to 17V. The device integrates low R<sub>DS(on)</sub> power MOSFETs, an accurate 0.6V ± 1% reference over the full operating junction temperature range and an integrated diode for the bootstrap circuit, offering a very compact solution.

The RTQ2806A adopts Advanced Constant On-Time (ACOT<sup>®</sup>) control architecture that provides excellent transient performance and reduces the external-component count of external components. In steady states, the ACOT<sup>®</sup> can operate at nearly constant switching frequency over line, load and output voltage ranges, making the EMI filter design easier.

The device offers a variety of functions provide more design flexibility. The selectable switching frequency, current limit level and PWM operation modes make the RTQ2806A easy-to-use over wide application range. An independent enable control input pin and power-good indicator are also provided for easy sequence control. The device provides a programmable soft-start-up by an external capacitor connected to the SS/TR pin to control the inrush current during start-up. The RTQ2806A provides complete protection functions including input undervoltage lockout, output undervoltage protection, output overvoltage protection, overcurrent protection, and over-temperature protection. The RTQ2806A is available in a thermally enhanced WQFN-14TL 2x3 (FC) package.

The recommended junction temperature range is -40°C to 150°C.

## 2 Features

- **Wide Input Voltage Range**
  - ▶ 2.7V to 17V with External 3.3V VCC Bias
  - ▶ 3.5V to 17V with Internal VCC Bias
- **Output Voltage from 0.6V to 5.5V**
- **0.6V ± 1% Voltage Reference from -40°C to 150°C Junction Temperature Range**
- **ACOT<sup>®</sup> Control for Excellent Transient Performance**
- **Stable with Ceramic Output Capacitors**
- **Selectable FCCM or PSM Operation at light load**
- **Selectable Operation Switching Frequency (660kHz/1100kHz/2200kHz)**
- **Non-Latch for OCP, OVP, UVP, UVLO, and OTP**
- **Power-Good Indicator**
- **Enable Control**
- **Programmable Soft-Start Time with a Default 2.2ms**
- **Programmable Valley Current Limit Level**
- **Monotonic Start-Up into Pre-Biased Outputs**
- **Output Voltage Tracking**
- **Small 14-Lead WQFN (2x3) (FC) Package (Pin Pitch 0.5mm)**

## 3 Applications

- Servers, Storage and Network Equipment
- Telecom Infrastructure
- Point of Load (POL) Power Modules
- High Density DC-DC Converters

## 4 Simplified Application Circuit

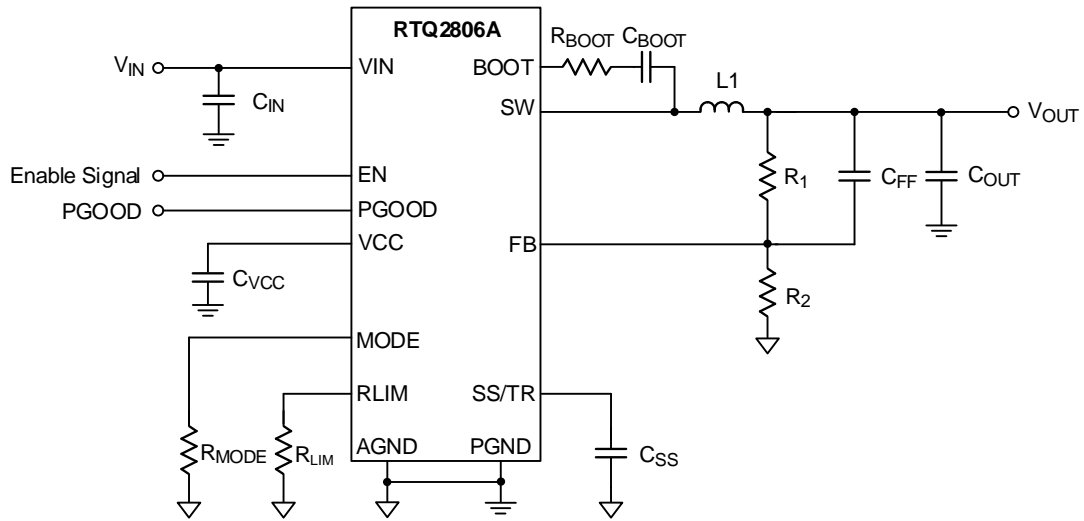

## 5 Ordering Information

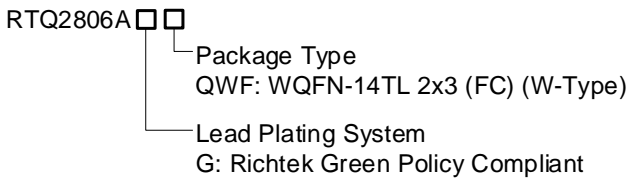

Note:

Richtek products are Richtek Green Policy compliant and compatible with the current requirements of IPC/JEDEC J-STD-020.

## 6 Marking Information

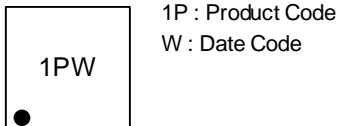

## 7 Pin Configuration

(TOP VIEW)

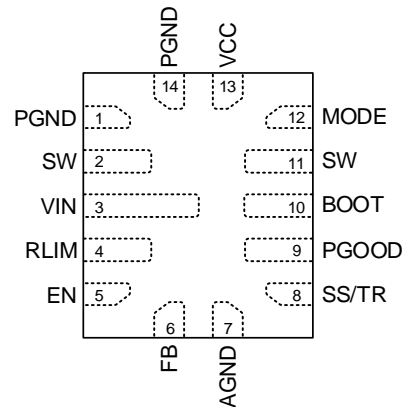

WQFN-14TL 2x3 (FC)

**Table of Contents**

**1 General Description-----1**

**2 Features-----1**

**3 Applications -----1**

**4 Simplified Application Circuit-----2**

**5 Ordering Information -----2**

**6 Marking Information -----2**

**7 Pin Configuration -----2**

**8 Functional Pin Description -----5**

**9 Functional Block Diagram -----6**

**10 Absolute Maximum Ratings -----7**

**11 ESD Ratings -----7**

**12 Recommended Operating Conditions -----7**

**13 Thermal Information -----7**

**14 Electrical Characteristics -----8**

**15 Typical Application Circuit----- 11**

**16 Typical Operating Characteristics----- 13**

**17 Operation----- 24**

    17.1 Power and Bias Supply----- 24

    17.2 Enable, Start-Up, Shutdown and UVLO----- 24

    17.3 Output Voltage Tracking and External Reference ----- 26

    17.4 Pre-Bias ----- 26

    17.5 Minimum On-Time and Minimum Off-Time ----- 27

    17.6 Mode Selection, Switching Frequency ----- 27

    17.7 Light Load Operation----- 28

    17.8 BOOT UVLO ----- 28

    17.9 Power-Good Output----- 28

    17.10 Overcurrent-limit protection ----- 29

    17.11 Output Undervoltage Protection and Hiccup Mode----- 29

    17.12 Negative Current Limit----- 30

    17.13 Output Overvoltage Protection ----- 30

    17.14 Output Quick Discharge Mode ----- 32

    17.15 Output Voltage Discharge ----- 32

    17.16 Over-Temperature Protection (OTP)----- 32

**18 Application Information----- 33**

    18.1 Switching Frequency and MODE Selection ----- 33

    18.2 Inductor Selection ----- 33

18.3	Input Capacitor Selection	34
18.4	Output Capacitor Selection	35
18.5	Internal VCC Regulator	36
18.6	Bootstrap Driver Supply	36
18.7	Output Voltage Programming	36
18.8	Feedforward Capacitor ( $C_{FF}$ )	37
18.9	Enable and Adjustable UVLO	38
18.10	Thermal Considerations	40
18.11	Layout Guidelines	41
<b>19</b>	<b>Outline Dimension</b>	<b>43</b>
<b>20</b>	<b>Footprint Information</b>	<b>44</b>
<b>21</b>	<b>Packing Information</b>	<b>45</b>
21.1	Tape and Reel Data	45
21.2	Tape and Reel Packing	46
21.3	Packing Material Anti-ESD Property	47

**8 Functional Pin Description**

Pin No.	Pin Name	Pin Function
1, 14	PGND	The power GND of the controller circuit and the regulated output voltage. Use wide PCB traces to make the connections.
2, 11	SW	Switch node. Output switching state between high-side MOSFET and low-side MOSFET of the power converter. Connect SW pin to the external inductor and bootstrap capacitor.
3	VIN	Power input voltage. Support 3.5V to 17V input voltage. It is suggested to place decoupling input capacitors as close to the VIN and PGND pins as possible.
4	RLIM	Valley current limit setup pin. Connect a resistor from this pin to AGND to set the valley current limit value. At least $\pm 1\%$ resistor is required.
5	EN	Enable control input. A logic-high enables the converter; however, a logic-low forces the device into shutdown mode. Do not leave this pin floating.
6	FB	Feedback voltage input. The pin is used to set the output voltage of the converter via a resistor divider. It is suggested to place the FB resistor divider as close to the FB pin as possible.
7	AGND	Analog ground. Reference point for the internal control circuit. AGND and PGND are connected with a short trace and at only one point to reduce circulating currents.
8	SS/TR	Soft-start and tracking control input. Connecting a ceramic capacitor from this pin to AGND programs the soft-start time. The internal minimum start-up time is 2.2ms (typ.). A minimum capacitor of 22nF on this pin is required. For the tracking function, the device can track the pin voltage as the reference for tracking applications because the SS/TR pin voltage can override the internal reference voltage.
9	PGOOD	Open-drain, power-good indication output. It is pulled low if the feedback voltage is out of the Power-Good voltage threshold, IC shutdown from fault state and EN goes low, and before the soft-start is finished. A pull-up resistor of 10k $\Omega$ to 100k $\Omega$ is recommended if this function is used.
10	BOOT	Bootstrap capacitor connection node to supply the high-side gate driver. Connect a 0.1 $\mu$ F, X7R ceramic capacitor between this pin and SW pin.
12	MODE	Mode selection setup pin. The mode pin can be set to force continuous-conduction mode (FCCM) or pulse skipping mode (PSM) for high light-load efficiency, and the operation switching frequency. At least $\pm 1\%$ resistor is required.
13	VCC	3V internal LDO output. An external DC voltage source 3.3V $\pm 5\%$ can be connected to this pin for less power losses on the internal LDO and supply both the internal circuitry and gate driver. Connect a 4.7 $\mu$ F, X7R ceramic capacitor as close to the VCC pin as possible. It is not recommended to connect VCC to supply other rails.

9 Functional Block Diagram

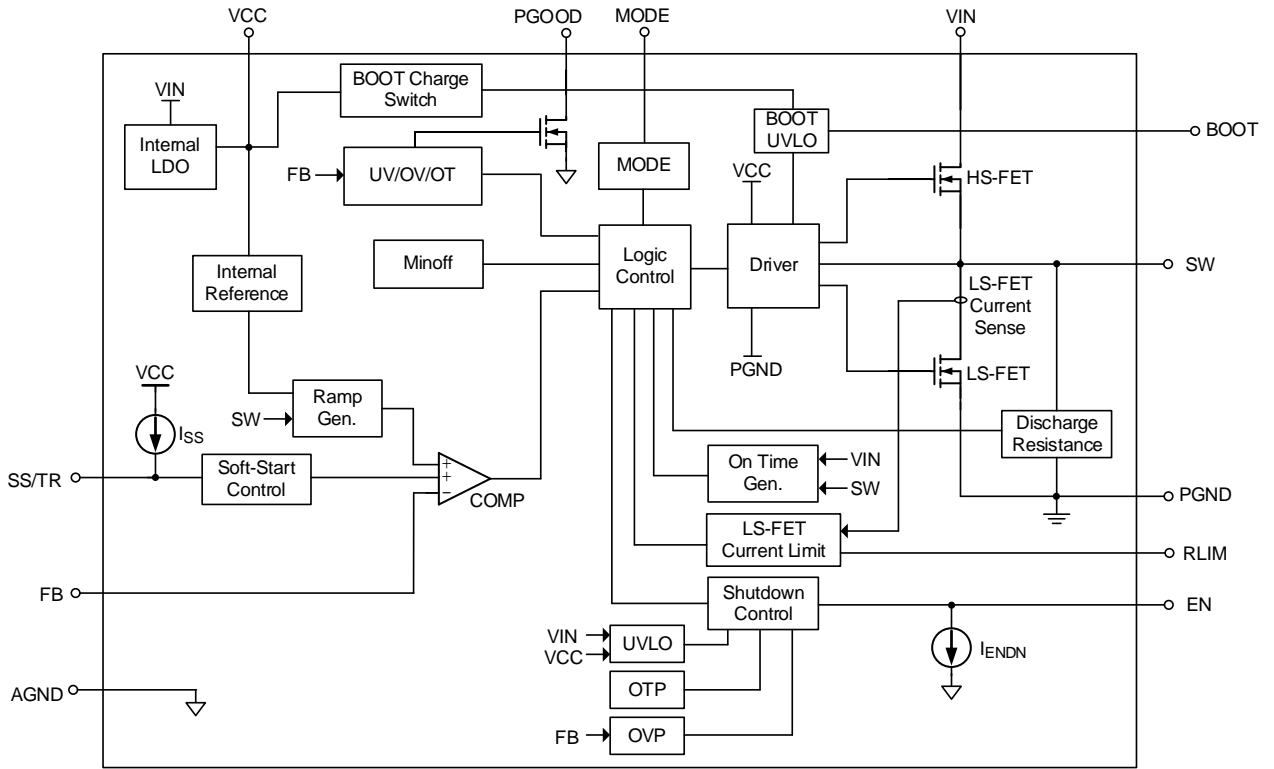

## 10 Absolute Maximum Ratings

(Note 1)

- VIN Voltage, VIN ----- -0.3V to 18V
- Enable Pin Voltage, VEN ----- -0.3V to 6V
- VIN to SW ----- -0.3V to 18V
- SW Voltage, VSW ----- -0.3V to 18.3V
- VSW (t ≤ 25ns) ----- -5V to 25V
- BOOT Voltage, VBOOT ----- -0.3V to 24V
- BOOT to SW Voltage (VBOOT-VSW) ----- -0.3V to 6V
- VCC ----- -0.3V to 6V
- All Other Pins ----- -0.3V to 6V
- Lead Temperature (Soldering, 10 sec.) ----- 260°C
- Junction Temperature ----- 170°C
- Storage Temperature Range ----- -65°C to 170°C

**Note 1.** Stresses beyond those listed under “Absolute Maximum Ratings” may cause permanent damage to the device. These are stress ratings only, and functional operation of the device at these or any other conditions beyond those indicated in the operational sections of the specifications is not implied. Exposure to absolute maximum rating conditions may affect device reliability.

## 11 ESD Ratings

(Note 2)

- ESD Susceptibility
- HBM (Human Body Model), All Other pins ----- 2kV

**Note 2.** Devices are ESD sensitive. Handling precautions are recommended.

## 12 Recommended Operating Conditions

(Note 3)

- VIN with Internal VCC Bias, VIN ----- 3.5V to 17V
- VIN with External 3.3V VCC Bias, VIN ----- 2.7V to 17V
- Output Voltage ----- 0.6V to 5.5V
- External VCC bias, VCC\_EXT ----- 3.12V to 3.6V
- Junction Temperature Range ----- -40°C to 150°C

**Note 3.** The device is not guaranteed to function outside its operating conditions.

## 13 Thermal Information

(Note 4 and Note 5)

Thermal parameter		WQFN-14TL 2x3 (FC)	Unit
θJA	Junction-to-ambient thermal resistance (JEDEC standard)	64.78	°C/W
θJC(Top)	Junction-to-case (top) thermal resistance	45.53	°C/W
θJC(Bottom)	Junction-to-case (bottom) thermal resistance	3.97	°C/W
θJA(EVB)	Junction-to-ambient thermal resistance (specific EVB)	37.88	°C/W

Thermal parameter		WQFN-14TL 2x3 (FC)	Unit
$\Psi_{JC(Top)}$	Junction-to-top characterization parameter	1.487	°C/W
$\Psi_{JB}$	Junction-to-board characterization parameter	19.64	°C/W

**Note 4.** For more information about thermal parameter, see the Application and Definition of Thermal Resistances report, AN061.

**Note 5.**  $\theta_{JA(EVB)}$ ,  $\Psi_{JC(TOP)}$  and  $\Psi_{JB}$  are measured on a high effective-thermal-conductivity four-layer test board which is in size of 92.2 mm x 81.4 mm; furthermore, all layers with 2 oz. Cu. Thermal resistance/parameter values may vary depending on the PCB material, layout, and test environmental conditions.

## 14 Electrical Characteristics

( $V_{IN} = 12V$ ,  $T_J = -40^{\circ}C$  to  $150^{\circ}C$ , typical values are at  $T_J = 25^{\circ}C$ , unless otherwise specified.)

Parameter	Symbol	Test Conditions	Min	Typ	Max	Unit
<b>Supply Current</b>						
Shutdown Current	ISHDN	$T_J = 25^{\circ}C$ , $V_{EN} = 0V$	--	5	15	$\mu A$
Supply Current (non-switching)	IQ_NSW	$T_J = 25^{\circ}C$ , $V_{EN} = 2V$ , non-switching	--	1050	1300	$\mu A$
<b>Logic Threshold</b>						
EN Input Voltage Rising Threshold	$V_{EN\_R}$		1.17	1.22	1.27	V
EN Threshold Hysteresis	$V_{EN\_HYS}$		--	200	--	mV
EN Pull-Down Current	IPD_EN	$T_J = 25^{\circ}C$ , $V_{EN} = 2V$	--	0.5	--	$\mu A$
<b>Reference Voltage</b>						
Internal Reference Voltage	$V_{REF}$	$T_J = -40^{\circ}C$ to $+150^{\circ}C$	0.594	0.6	0.606	V
		$T_J = 0^{\circ}C$ to $+70^{\circ}C$	0.597	0.6	0.603	V
<b>Soft-Start and Tracking</b>						
Internal Soft-Start Time	tSS	$T_J = 25^{\circ}C$ , $C_{SS} = 22nF$ , $V_{OUT}$ is 0% to 100% (Note 6)	--	2.2	--	ms
SS/TR Source Current	ISS/TR_sr	$V_{SS/TR} = 0V$	--	15	--	$\mu A$
SS/TR Sink Current	ISS/TR_sk	$V_{SS/TR} = 0.7V$	--	6	--	$\mu A$
<b>MOSFET</b>						
On-Resistance of High-side MOSFET	$R_{DS(on)_H}$	$T_J = 25^{\circ}C$ , $V_{CC} = 3V$	--	22.6	--	m $\Omega$
On-Resistance of Low-side MOSFET	$R_{DS(on)_L}$	$T_J = 25^{\circ}C$ , $V_{CC} = 3V$	--	8.1	--	
<b>Current Limit</b>						
Current Limit Voltage Threshold	$V_{LIM}$	$T_J = 25^{\circ}C$ , valley current	1.15	1.2	1.25	V
Ics to IOUT Ratio	Gcs (Ics/IOUT)	$I_{OUT} \geq 2A$	36	40	44	$\mu A/A$
Low-Side Switch (Valley) Current Limit	$I_{LIM\_L}$	$T_J = 25^{\circ}C$ , valley current, $R_{LIM} = 3.75k\Omega$	--	8	--	A
Low-Side Switch Negative Current Limit	$I_{LIM\_NEG}$	$T_J = 25^{\circ}C$ , valley current	--	-8	--	A



Parameter	Symbol	Test Conditions	Min	Typ	Max	Unit
<b>Switching Frequency</b>						
Switching Frequency	f <sub>SW</sub>	R <sub>MODE</sub> = 60.4kΩ, I <sub>OUT</sub> = 0A, FCCM, V <sub>OUT</sub> = 1.8V	530	660	790	kHz
		R <sub>MODE</sub> = 0Ω, I <sub>OUT</sub> = 0A, FCCM, V <sub>OUT</sub> = 1.8V	935	1100	1265	
		R <sub>MODE</sub> = 30.1kΩ, I <sub>OUT</sub> = 0A, FCCM, V <sub>OUT</sub> = 3.3V	1870	2200	2530	
<b>On-Time Timer Control</b>						
Minimum On-Time	t <sub>ON_MIN</sub>	T <sub>J</sub> = 25°C (Note 6)	--	--	50	ns
Minimum Off-Time	t <sub>OFF_MIN</sub>	T <sub>J</sub> = 25°C (Note 6)	--	--	180	ns
<b>UVLO</b>						
Input Undervoltage Lockout Rising Threshold	V <sub>UVLO_R</sub>	V <sub>IN</sub> rising, V <sub>CC_EXT</sub> = 3.3V	2.1	2.4	2.7	V
Input Undervoltage Lockout Hysteresis	V <sub>UVLO_HYS</sub>	V <sub>IN</sub> hysteresis	--	550	--	mV
<b>LDO Output</b>						
LDO Output Voltage	V <sub>CC</sub>	I <sub>VCC</sub> = 1mA	2.88	3.00	3.18	V
V <sub>CC</sub> Undervoltage Lockout Rising Threshold	V <sub>CC_UVLO_R</sub>	V <sub>CC</sub> rising	2.65	2.8	2.95	V
V <sub>CC</sub> Undervoltage Lockout Hysteresis	V <sub>CC_UVLO_HYS</sub>	V <sub>CC</sub> hysteresis	--	300	--	mV
V <sub>CC</sub> Load Regulation		T <sub>J</sub> = 25°C, I <sub>VCC</sub> = 25mA	--	0.5	--	%
LDO Output Current Limit	I <sub>LIM_LDO</sub>		--	105	--	mA
<b>Output Overvoltage and Undervoltage Protections</b>						
Output Undervoltage Protection Threshold	V <sub>UVP</sub>	UVP detect	77	80	83	%V <sub>REF</sub>
Output Overvoltage Protection Threshold	V <sub>OVP</sub>	OVP detect	113	116	119	%V <sub>REF</sub>
<b>Power-Good</b>						
Power-Good Voltage Threshold	V <sub>TH_PGLH1</sub>	V <sub>FB</sub> rising threshold, PGOOD from low to high (GOOD)	89.5	91.5	95.5	%V <sub>REF</sub>
	V <sub>TH_PGHL1</sub>	V <sub>FB</sub> rising threshold, PGOOD from high to low (FAULT)	113	116	119	
	V <sub>TH_PGLH2</sub>	V <sub>FB</sub> falling threshold, PGOOD from low to high (GOOD)	102	106	109	
	V <sub>TH_PGHL2</sub>	V <sub>FB</sub> falling threshold, PGOOD from high to low (FAULT)	77	80	83	

Parameter	Symbol	Test Conditions	Min	Typ	Max	Unit
Power-Good Output Low-Level Voltage	VPG_L_100	T <sub>J</sub> = 25°C, V <sub>IN</sub> & V <sub>CC</sub> & V <sub>EN</sub> = 0V, PGOOD Pull up to 3.3V bias with 100k resistor	--	650	850	mV
	VPG_L_10	T <sub>J</sub> = 25°C, V <sub>IN</sub> & V <sub>CC</sub> & V <sub>EN</sub> = 0V, PGOOD Pull up to 3.3V bias with 10k resistor	--	800	1000	
Power-Good Delay	tPGDLY	T <sub>J</sub> = 25°C, V <sub>TH_PGLH1</sub> and V <sub>TH_PGLH2</sub> , PGOOD from low to high (GOOD)	0.5	0.8	1.1	ms
<b>Over-Temperature Protection</b>						
Over-Temperature Protection Threshold	TOTP		150	160	--	°C
Over-Temperature Protection Hysteresis	TOTP_HYS		--	20	--	°C
<b>Output Discharge Resistor</b>						
Output Discharge Resistor	RDISCHG	V <sub>EN</sub> = 0V or Protection	--	80	--	Ω

**Note 6.** Guaranteed by design.

15 Typical Application Circuit

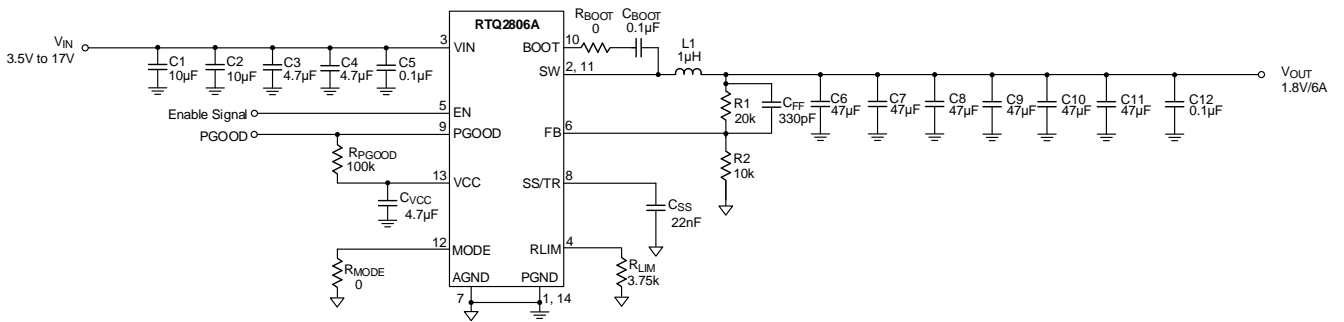

Table 1. Suggested Component Selection for the Application of 660kHz

V <sub>OUT</sub> (V)	R1 (kΩ)	R2 (kΩ)	L1 (µH)	C <sub>OUT_MIN</sub> (µF)	C <sub>OUT_TYPICAL</sub> (µF)	C <sub>FF</sub> (pF)
1.2	10	10	1	174	282	330
1.8	20		1.5	174	282	330
3.3	45.3		2.2	174	282	220
5	73.2		3.3	174	282	220

Table 2. Suggested Component Selection for the Application of 1100kHz

V <sub>OUT</sub> (V)	R1 (kΩ)	R2 (kΩ)	L1 (µH)	C <sub>OUT_MIN</sub> (µF)	C <sub>OUT_TYPICAL</sub> (µF)	C <sub>FF</sub> (pF)
1.2	10	10	0.68	174	282	330
1.8	20		1	174	282	330
3.3	45.3		1.5	174	282	220
5	73.2		2.2	174	282	220

Table 3. Suggested Component Selection for the Application of 2200kHz

V <sub>OUT</sub> (V)	R1 (kΩ)	R2 (kΩ)	L1 (µH)	C <sub>OUT_MIN</sub> (µF)	C <sub>OUT_TYPICAL</sub> (µF)	C <sub>FF</sub> (pF)
1.2	10	10	0.33	174	282	330
1.8	20		0.47	174	282	330
3.3	45.3		0.68	174	282	220
5	73.2		1	174	282	220

Table 4. Suggested Inductors for Typical Application Circuit

Inductance (µH)	Part No.	I <sub>SAT</sub> (A)	DCR (mΩ)	Dimensions (mm)	Component Supplier
0.22	744373460022	54.3	2.8	7.3 x 6.6 x 2.8	WE-LHMI
0.33	744373460033	47	3.9	7.3 x 6.6 x 2.8	WE-LHMI
0.47	744373460047	37.8	4.2	7.3 x 6.6 x 2.8	WE-LHMI
0.68	744373460068	31.6	5.5	7.3 x 6.6 x 2.8	WE-LHMI
1	74437346010	29	10	7.3 x 6.6 x 2.8	WE-LHMI
1.5	74437346015	27.6	15	7.3 x 6.6 x 2.8	WE-LHMI
2.2	74437346022	19.1	20	7.3 x 6.6 x 2.8	WE-LHMI
3.3	744311330	11	17.2	7 x 6.9 x 3.8	WE-HCI

Table 5. Suggested Capacitors for Typical Application Circuit

Capacitance ( $\mu$ F)	Part No.	Case Size	Component Supplier
47	GRM31CR60J476ME19L	1206	Murata
10	GRM31CR71E106KA12L	1206	Murata
4.7	GRM31CR71H475KA12	1206	Murata
0.1	0402B104K500CT	0603	WALSIN

Note: (1) All the input and output capacitors are the suggested values, referring to the effective capacitances, subject to any de-rating effect, like a DC Bias.

16 Typical Operating Characteristics

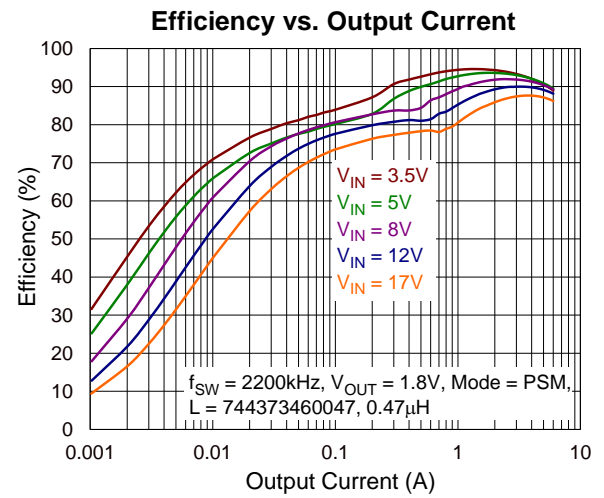
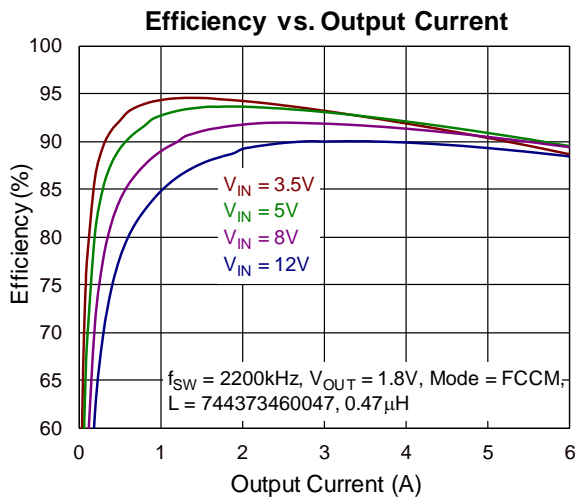
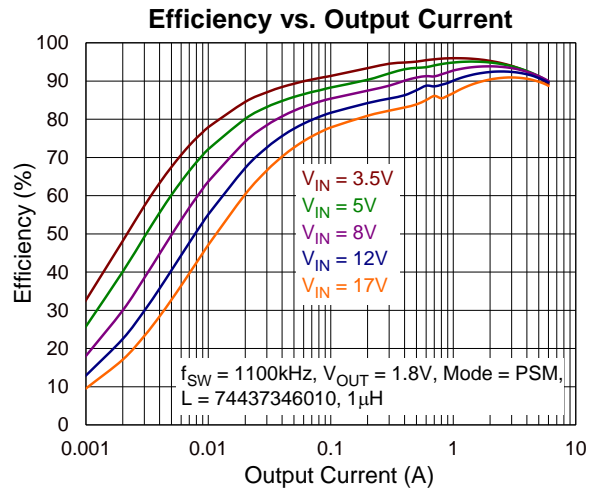
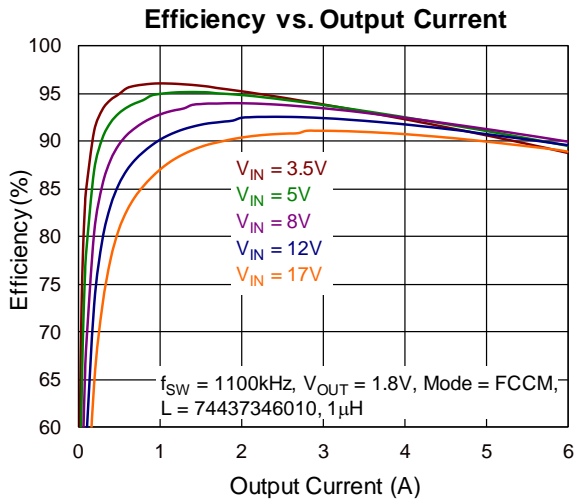
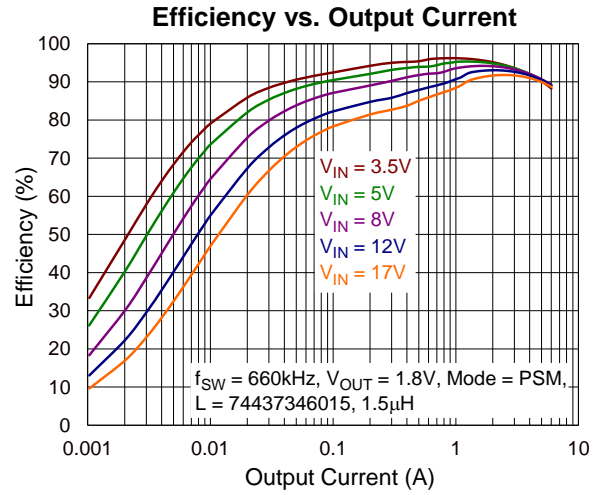
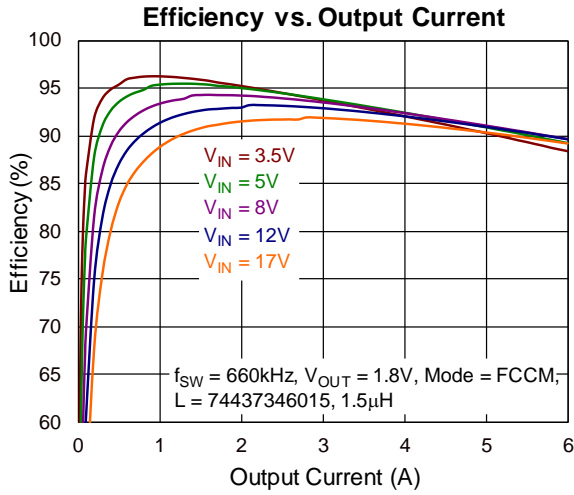

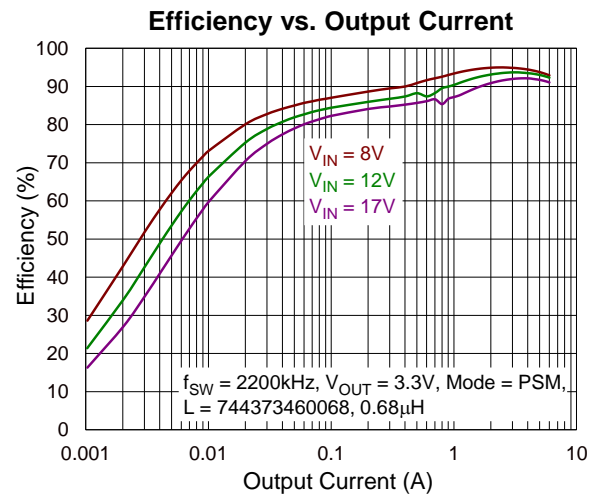
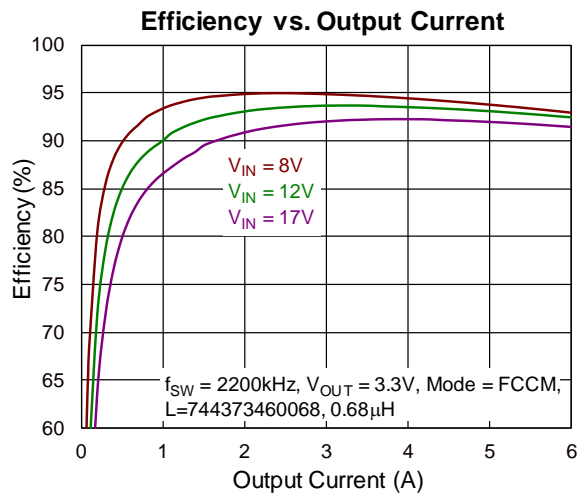
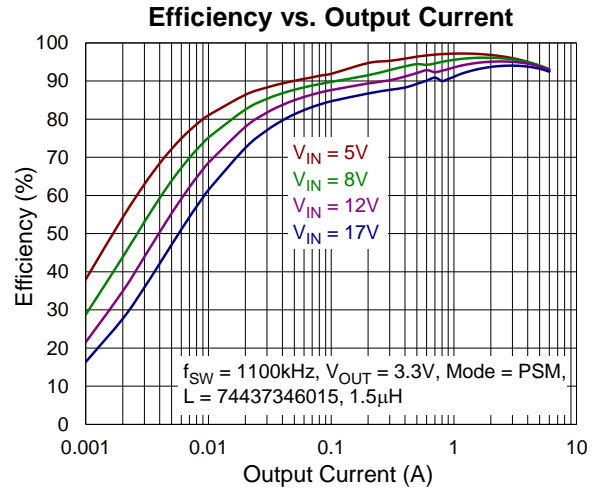
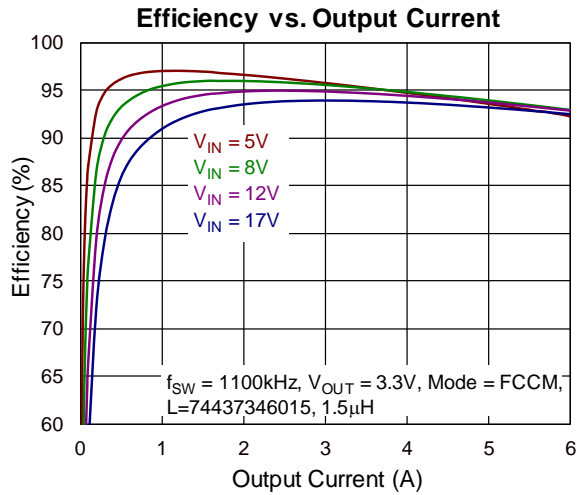
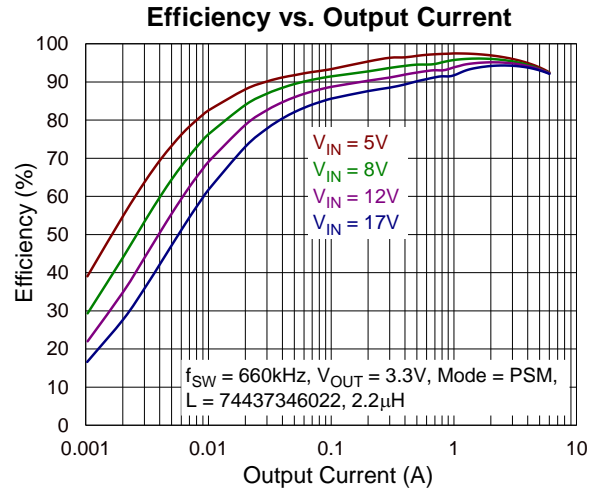
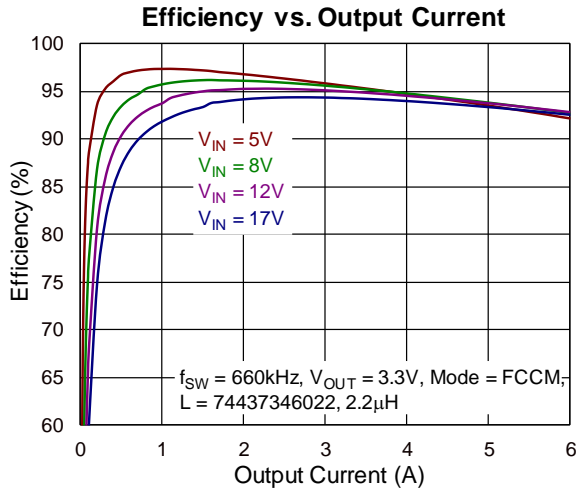

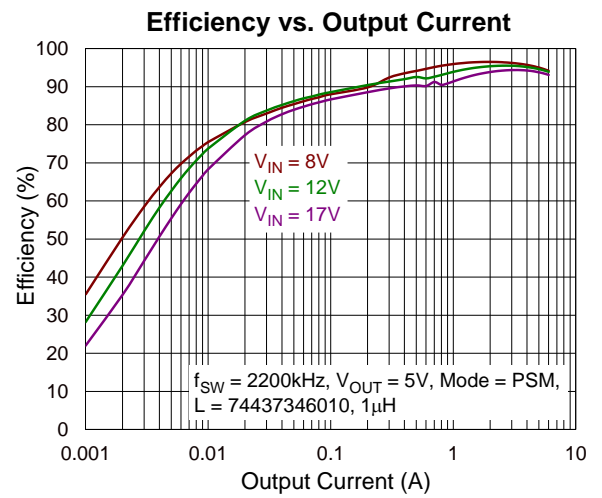
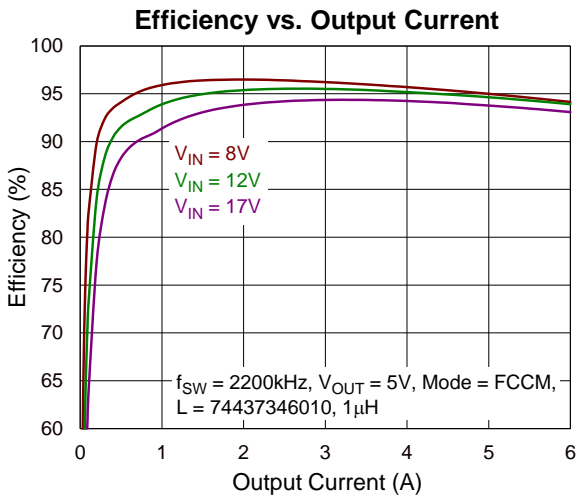
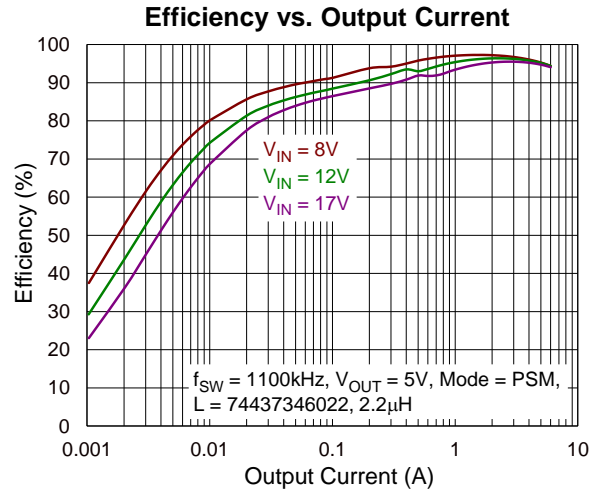
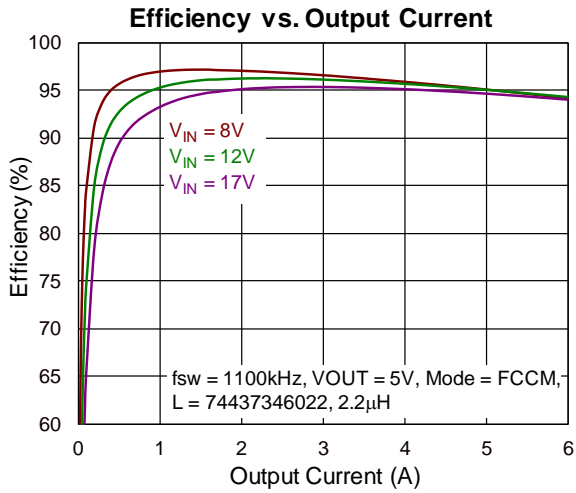
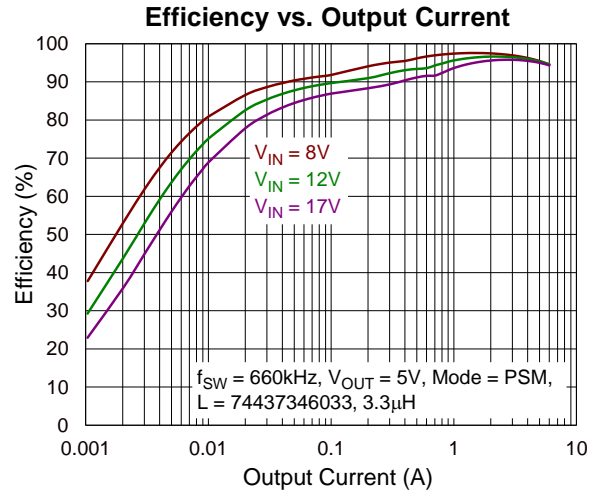
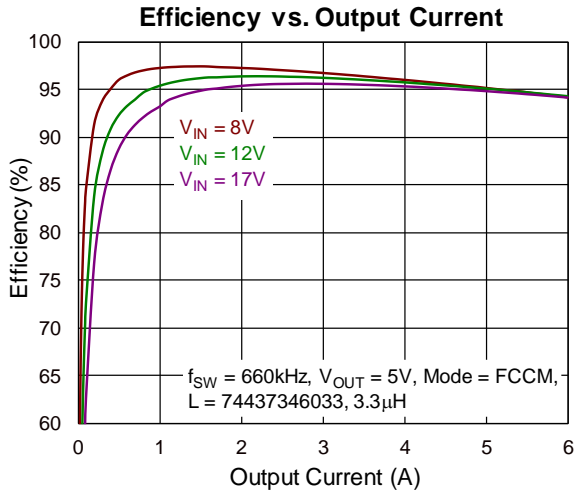

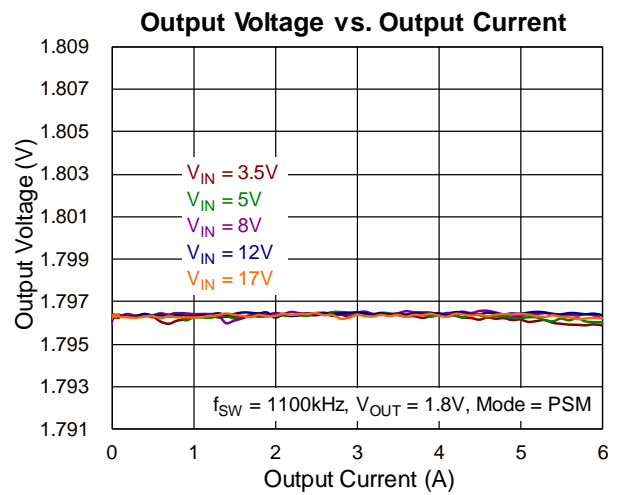
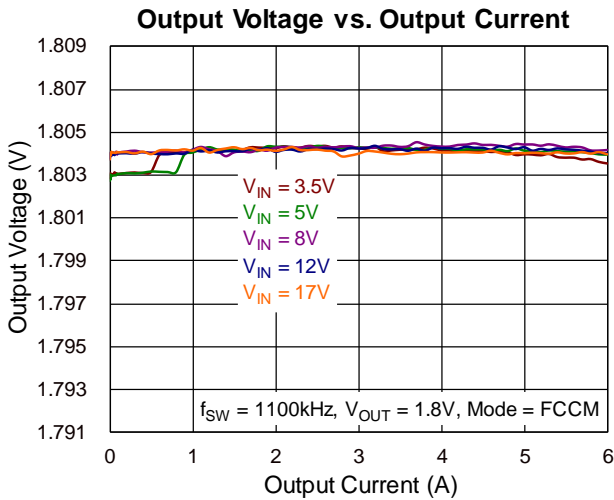
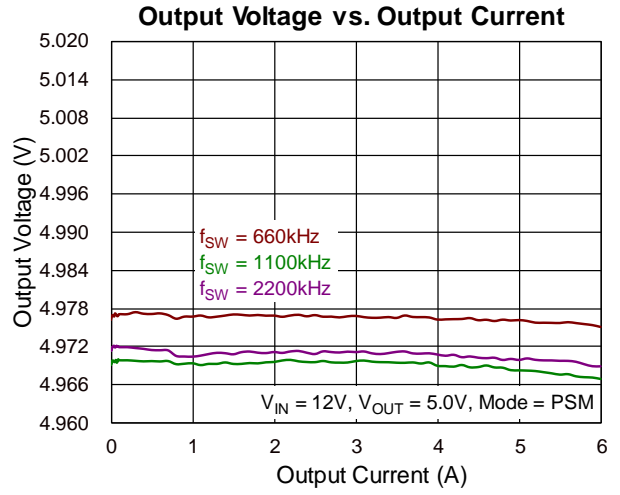
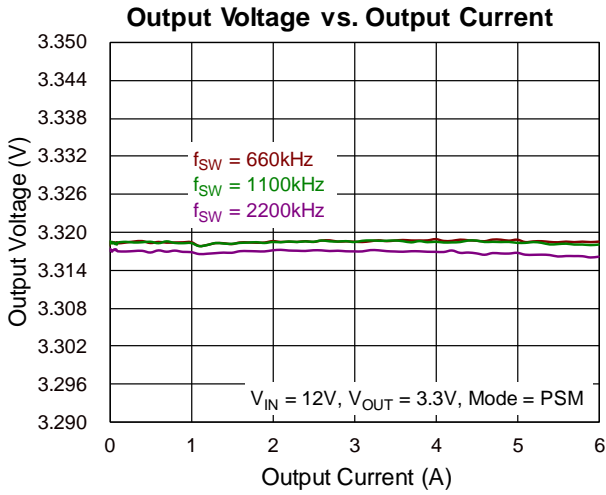
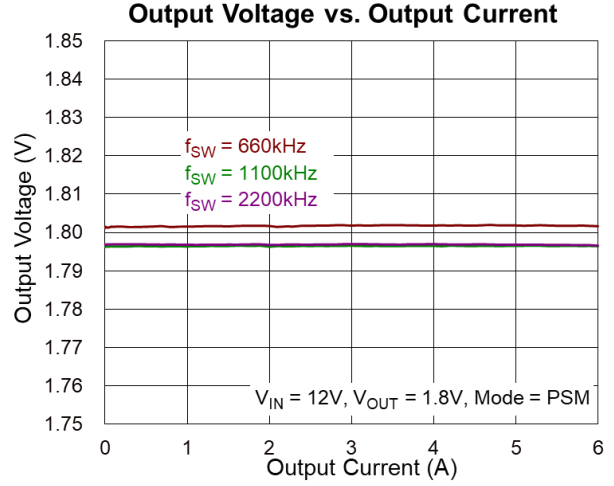
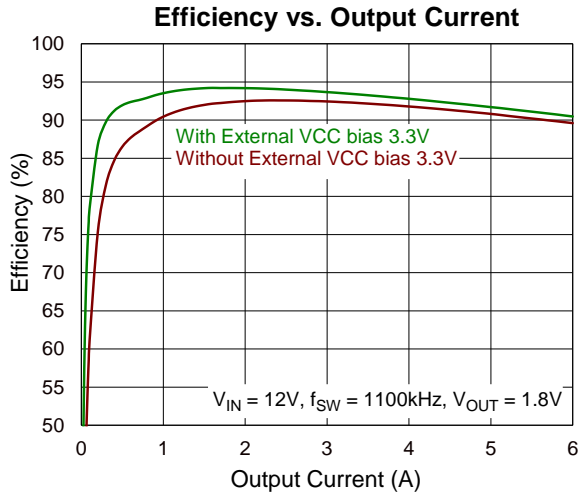



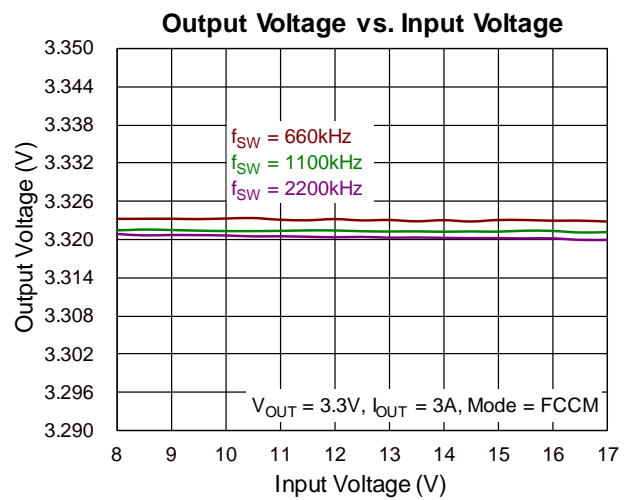
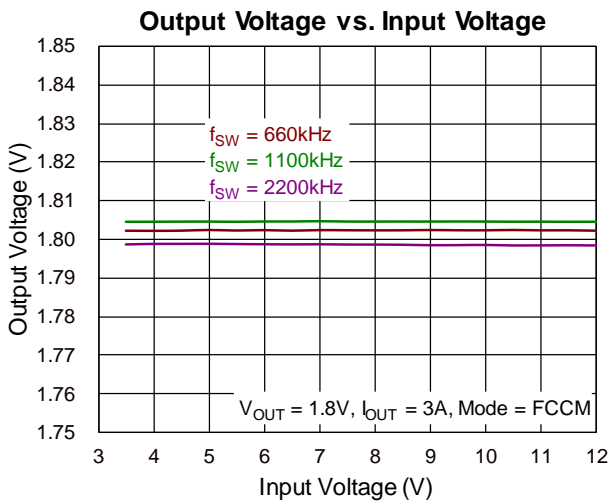
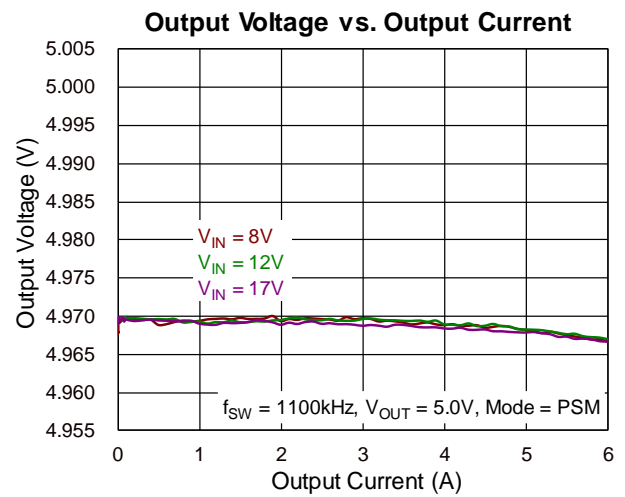
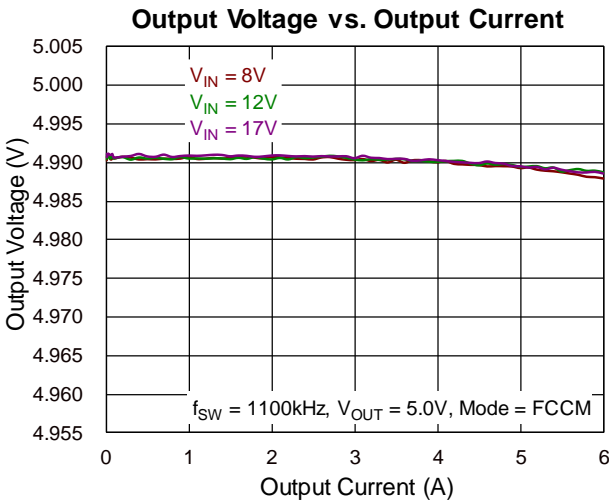
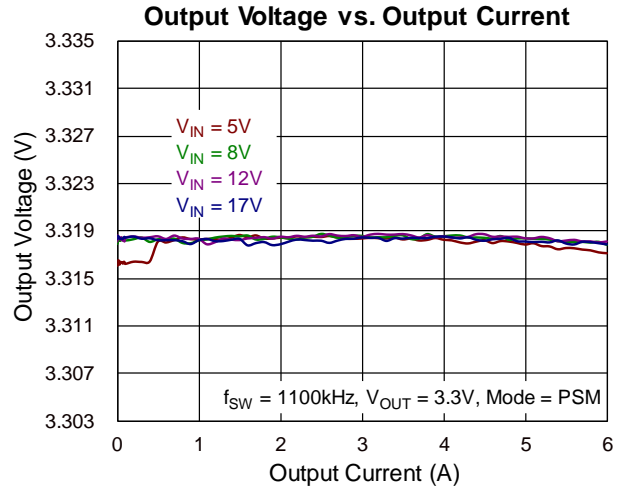
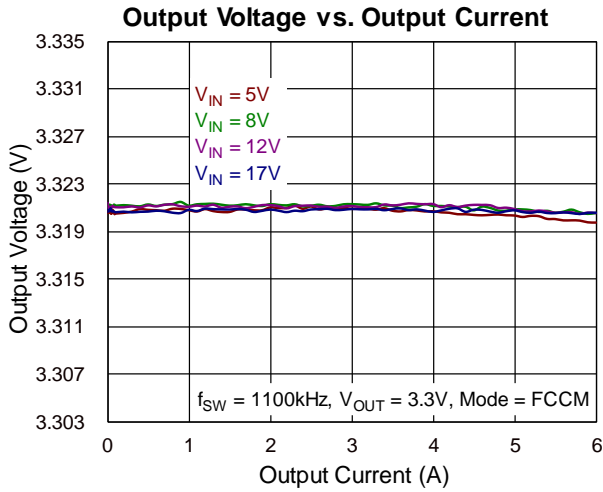

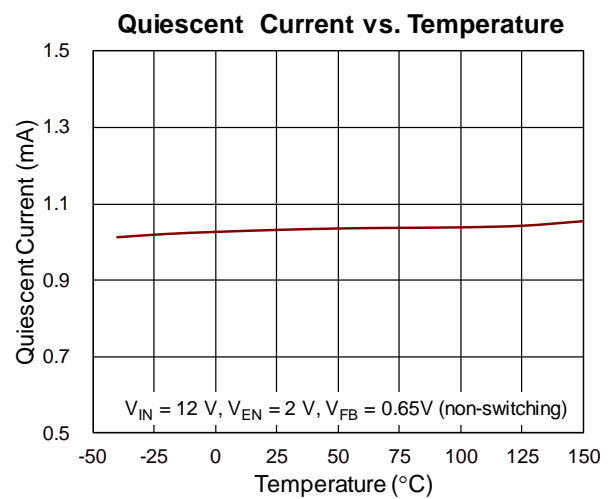
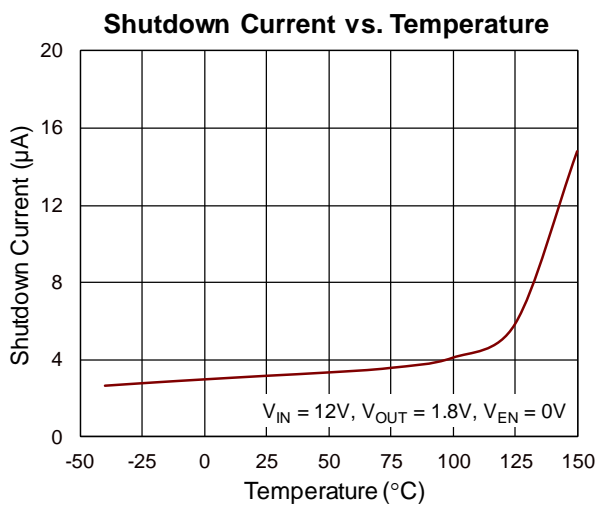
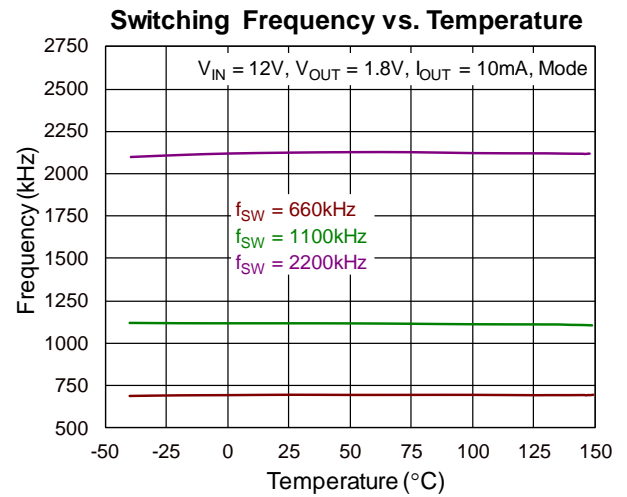
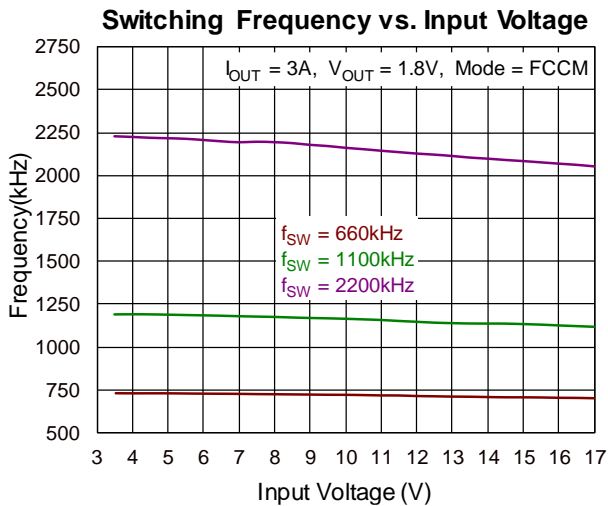
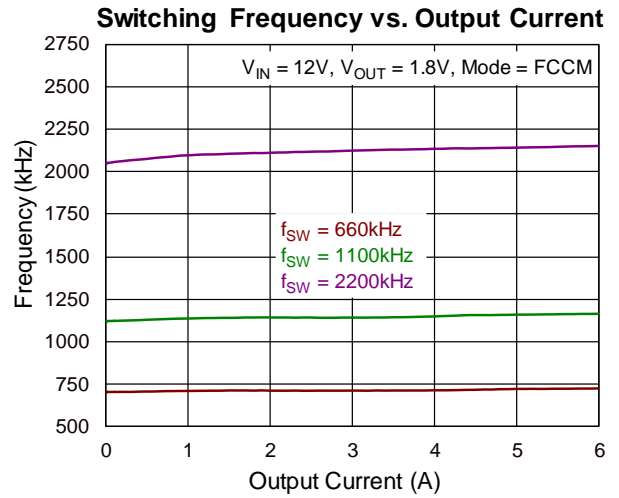
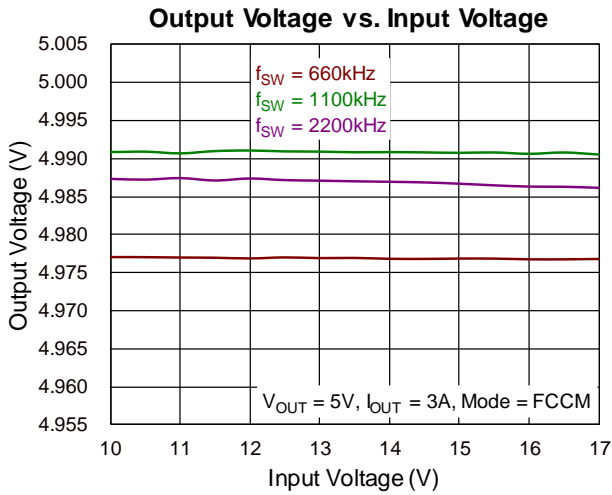

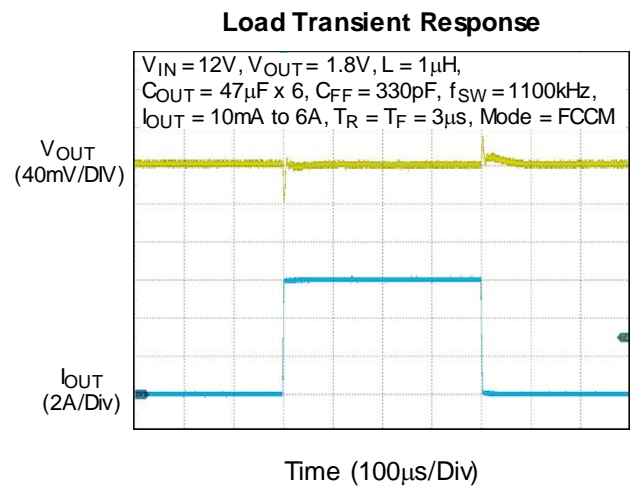
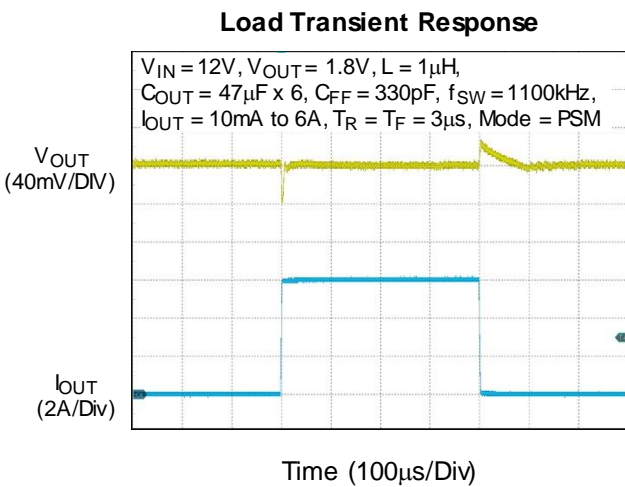
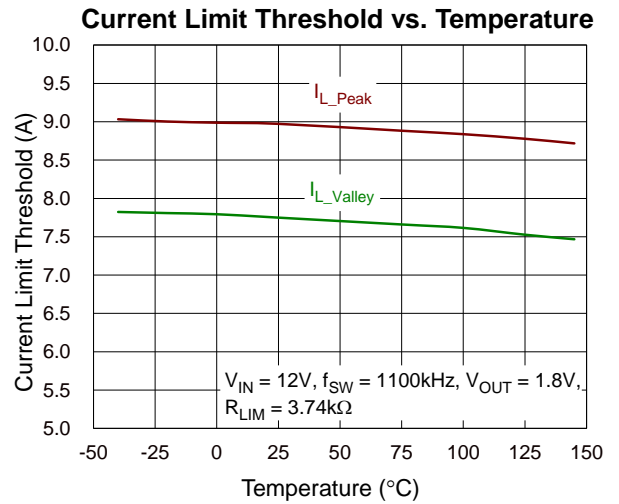
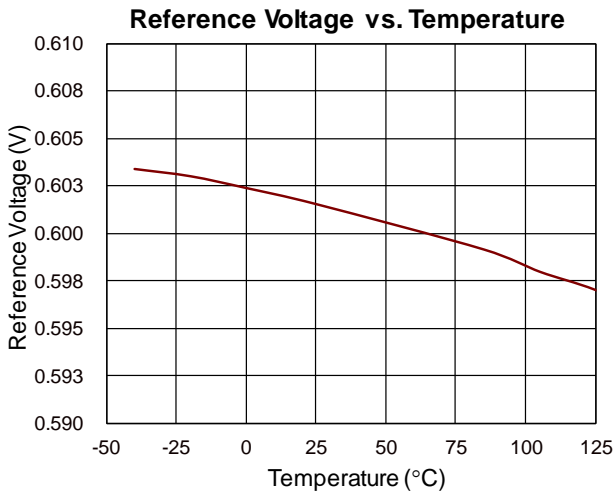
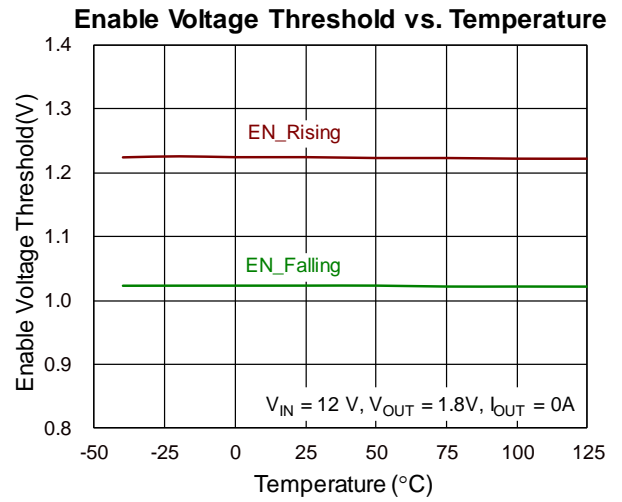
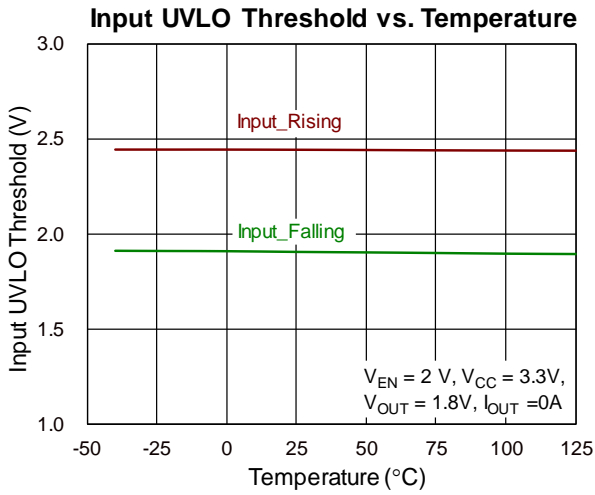

Load Transient Response

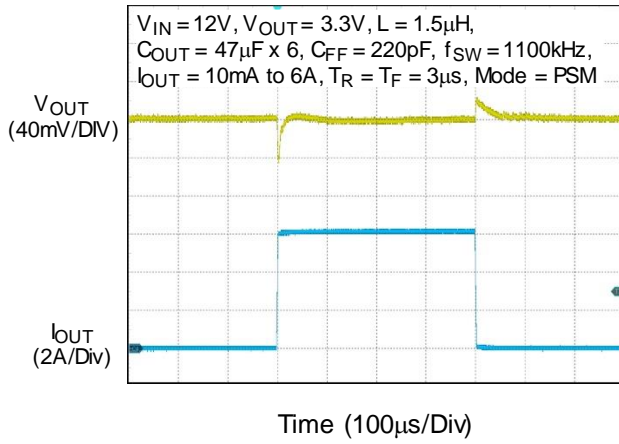

Load Transient Response

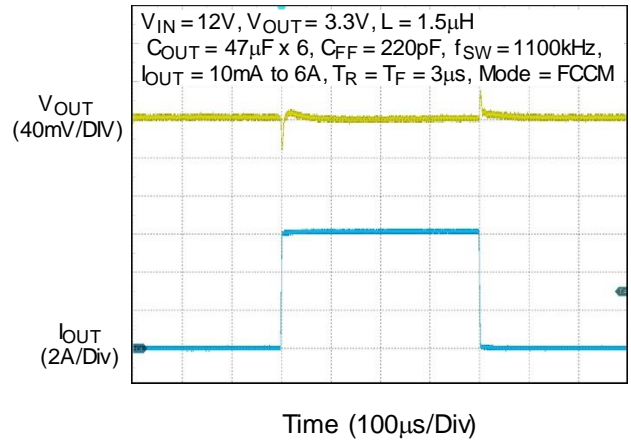

Load Transient Response

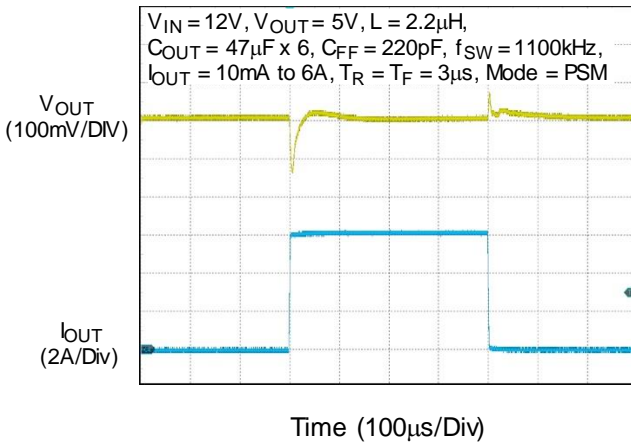

Load Transient Response

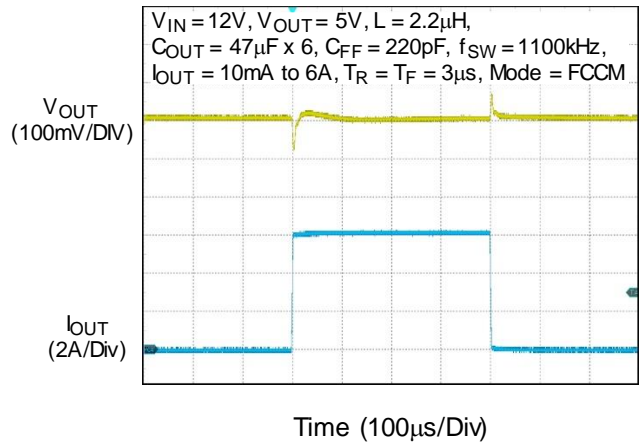

Output Ripple Voltage

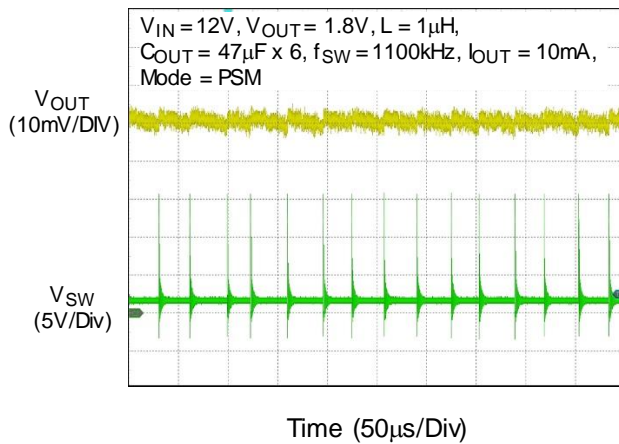

Output Ripple Voltage

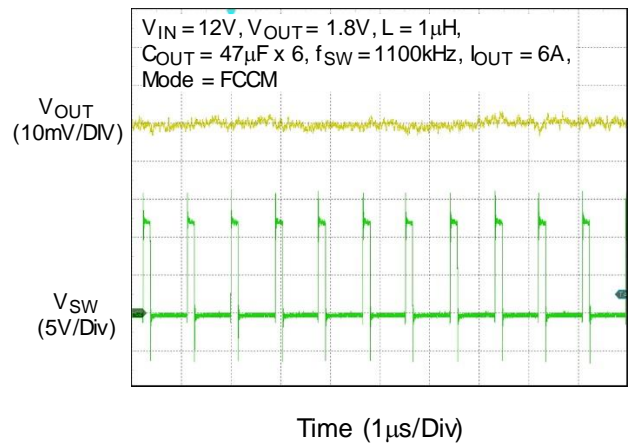

**Output Ripple Voltage**

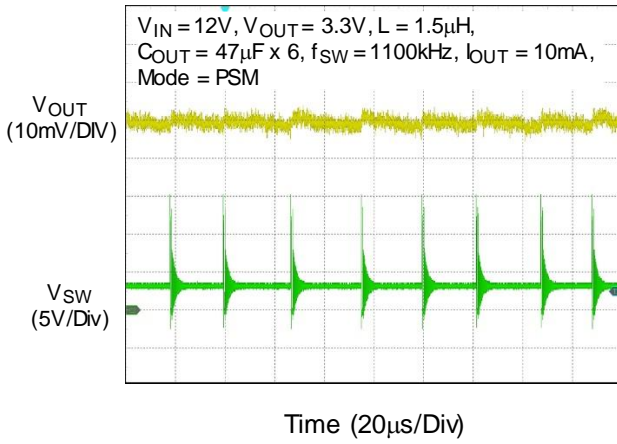

**Output Ripple Voltage**

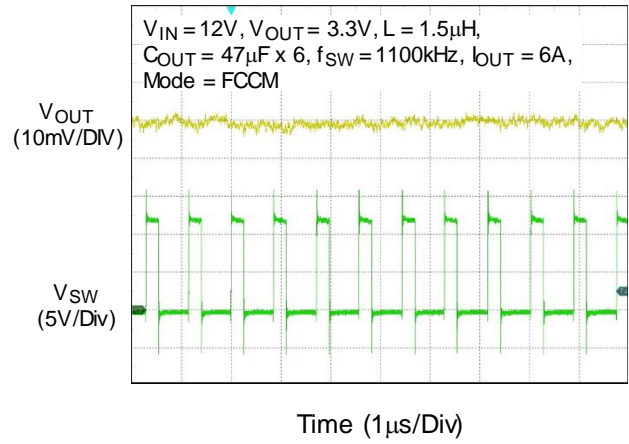

**Output Ripple Voltage**

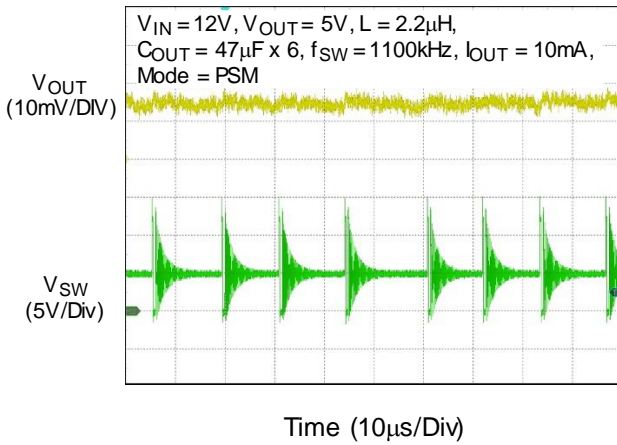

**Output Ripple Voltage**

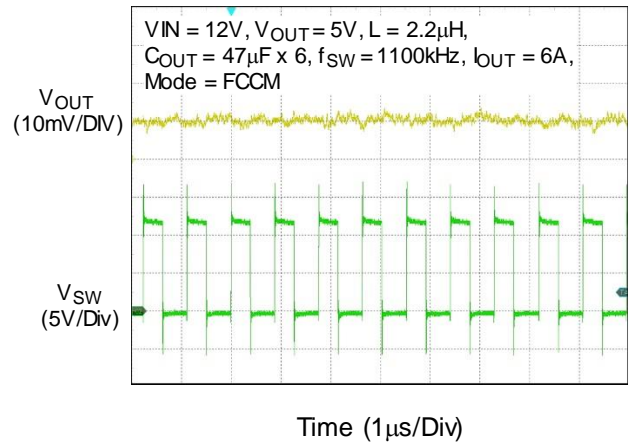

**Power On from EN**

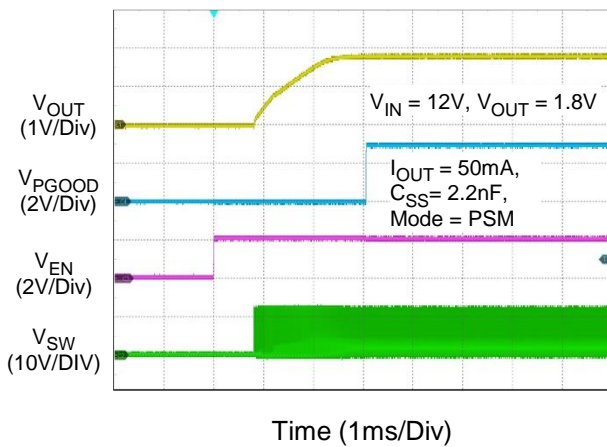

**Power Off from EN**

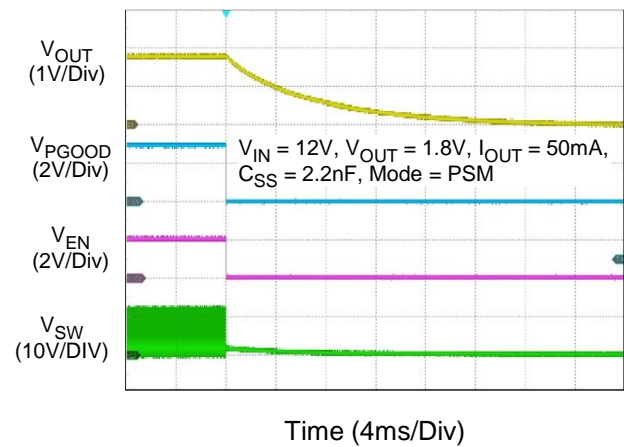



Power On from EN

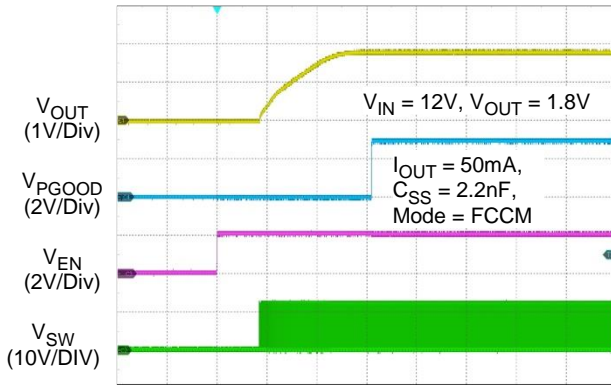

Time (1ms/Div)

Power Off from EN

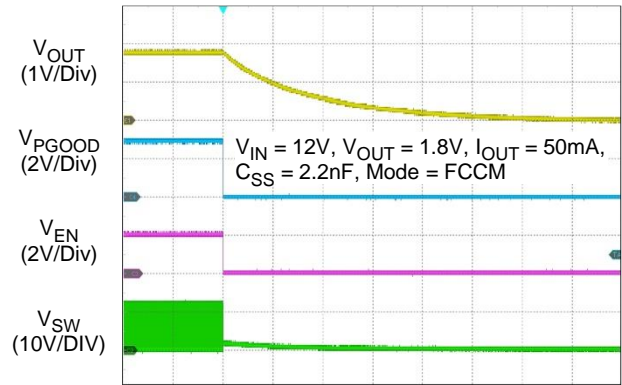

Time (4ms/Div)

Power On from EN

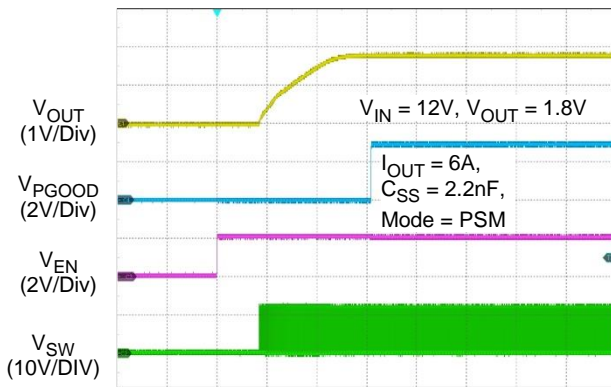

Time (1ms/Div)

Power Off from EN

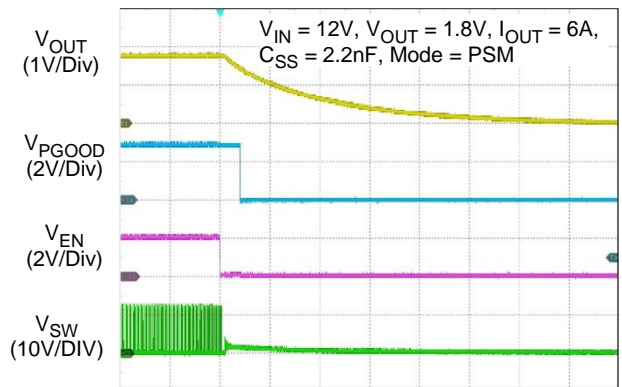

Time (50μs/Div)

Power On from VIN

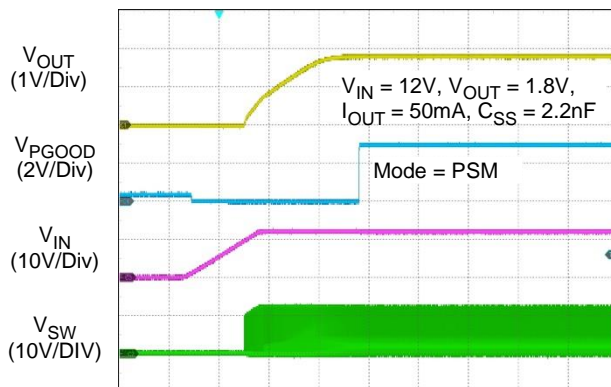

Time (1ms/Div)

Power Off from VIN

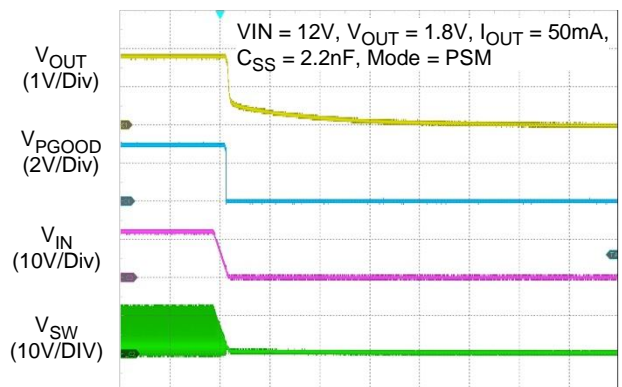

Time (5ms/Div)

Power On from VIN

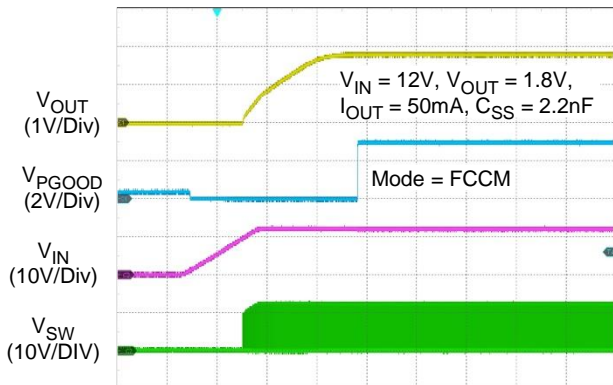

Time (1ms/Div)

Power Off from VIN

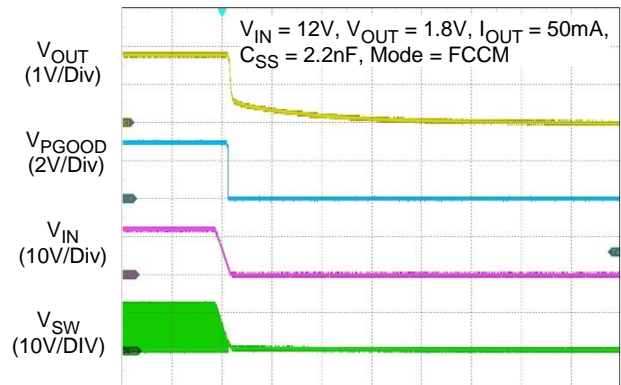

Time (5ms/Div)

Power On from VIN

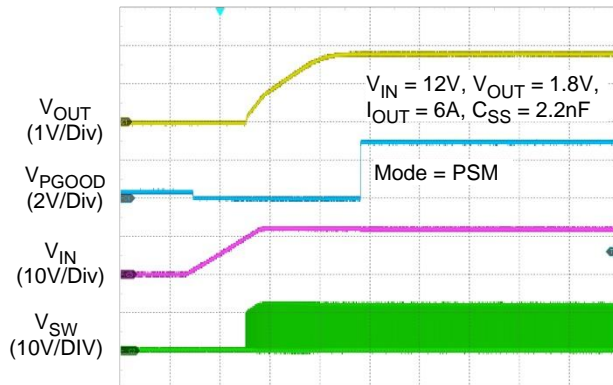

Time (1ms/Div)

Power Off from VIN

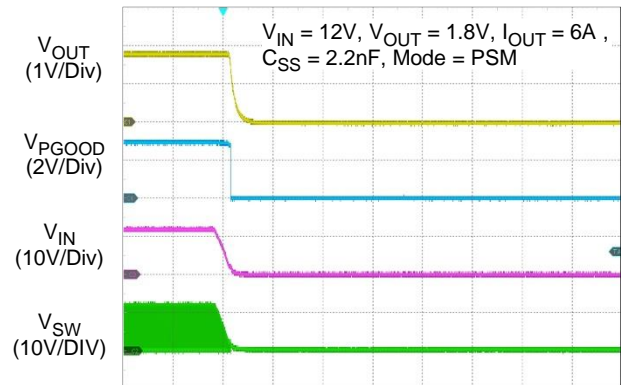

Time (1ms/Div)

## 17 Operation

The RTQ2806A is a high-efficiency synchronous step-down converter that utilizes the proprietary Advanced Constant On-Time (ACOT<sup>®</sup>) control architecture. The ultrafast ACOT<sup>®</sup> control enables the use of small capacitance to reduce PCB size.

During normal operation, the internal high-side MOSFET (HS-FET) turns on for a fixed interval determined by a one-shot timer at the beginning of each clock cycle. When the high-side MOSFET turns off, the low-side MOSFET (LS-FET) turns on. Due to the output capacitor ESR, the voltage ripple on the output has a similar shape to the inductor current. Via the feedback resistor network, this voltage ripple is compared with the internal reference. When the minimum off-time one-shot (180ns, max.) has timed out and the inductor current is below the current-limit threshold, the one-shot is triggered again if the feedback voltage falls below the internal VREF (0.6V, typ.). The RTQ2806A supports stable operation with all low-ESR output capacitors (such as ceramic capacitor and low ESR polymer capacitor). The ACOT<sup>®</sup> control architecture also features excellent transient response, further improving the output variation during high-frequency load transients, especially when a load suddenly increases. The conventional COT controller implements the on-time to be inversely proportional to input voltage and directly proportional to the output voltage to achieve pseudo-fixed frequency over the input voltage range. However, even with defined input and output voltages, a fixed ON time means that the frequency has to increase at higher load levels to compensate for the power losses in the MOSFETs and the inductor. The ACOT<sup>®</sup> control further adds a frequency locked loop system, which slowly adjusts the ON time to compensate for the power losses without influencing the fast transient behavior of the COT topology.

### 17.1 Power and Bias Supply

The VIN pins on the RTQ2806A supply voltage to the drain terminal of the internal high-side MOSFET. These pins also supply bias voltage for an internal regulator that generates 3V at the VCC pin. The voltage on the VCC pin is used for internal chip bias and gate drive for the low-side MOSFET. The gate drive for the high-side MOSFET is supplied by a floating supply (C<sub>BOOT</sub>) between the BOOT and SW pins. C<sub>BOOT</sub> is charged by BOOT charge switch through VCC. In addition, an internal charge pump maintains that the C<sub>BOOT</sub> voltage, which is sufficient to turn on the high-side MOSFET.

To improve efficiency and limit power dissipation in the VIN, an external voltage that is higher than the LDO's internal output voltage can override the internal LDO. When using an external bias on the VCC rail, any power-up and power-down sequencing can be applied. However, it is important to understand that if there is a discharge path on the VCC rail that can draw a current higher than the internal LDO's current limit from the VCC, then the VCC drops below the VCC UVLO falling threshold and causes the output of the RTQ2806A to shut down.

### 17.2 Enable, Start-Up, Shutdown and UVLO

The RTQ2806A implements undervoltage lockout protection (UVLO) to prevent operation without fully turning on the internal power MOSFETs. The UVLO monitors the internal LDO regulator voltage. When the VCC voltage is lower than the UVLO threshold voltage, the device is shutdown.

The EN pin is provided to control the device turn-on and turn-off. When the EN pin voltage is above the turn-on threshold (V<sub>EN\_R</sub>), the device is enabled. When the EN pin voltage falls below the turn-off threshold (V<sub>EN\_F</sub>), RTQ2806A is disabled. If the EN pin is floating, the RTQ2806A internally pulls down the EN pin continuously.

When the EN pin voltage rises above the enable threshold voltage, and VCC rises above the VCC\_UVLO\_R, the device enters its start-up sequence and initiate a soft-start ramp of the output voltage. An internal soft-start ramp of 2.2ms (typ.) will limit the ramp rate of the output voltage to prevent excessive input current during start-up. If a longer ramp time is desired, a capacitor C<sub>SS</sub> can be placed between the SS/TR pin and the AGND pin. The SS/TR



pin provide the source current to create a voltage ramp on the  $C_{SS}$ . If this external ramp rate is slower than the internal 2.2ms soft-start, the output voltage will be limited by the ramp rate on the SS/TR pin instead. However, if a longer soft-start time is desired, the device supports watchdog function for abnormal period of soft-start time. When it exceeds 10ms, it will activate output undervoltage protection. The typical external soft-start time can be calculated by the equation below.

$$C_{SS} \text{ (nF)} = \frac{t_{SS} \text{ (ms)} \times 15 \text{ (\mu A)}}{0.6 \text{ V}}$$

When the  $V_{EN}$  is lower than  $V_{EN\_F}$ , the voltage of the SS/TR pin discharges to AGND.

Figure 1 below shows the typical power-up sequence of the device. When the voltage on the  $V_{IN}$  and  $V_{EN}$  pins crosses the input undervoltage lockout rising threshold and  $V_{EN}$  input rising threshold. After the voltage on the  $V_{CC}$  pin reaches the  $V_{CC}$  undervoltage lockout rising threshold. The device will start switching if the voltage difference between the SS/TR pin and FB pin is equal to 300mV (i.e.  $V_{SS/TR} - V_{FB} = 300\text{mV}$ , typ.) after setting detection is completed. The SS/TR pin should never be left unconnected for soft-start control. After the  $V_{FB}$  rises above the  $V_{TH\_PGLH1}$  (91.5% of  $V_{REF}$ , typ.), the  $P_{GOOD}$  pin will enter a high impedance state after delay time  $t_{PGDLY}$  (0.8ms, typ.).

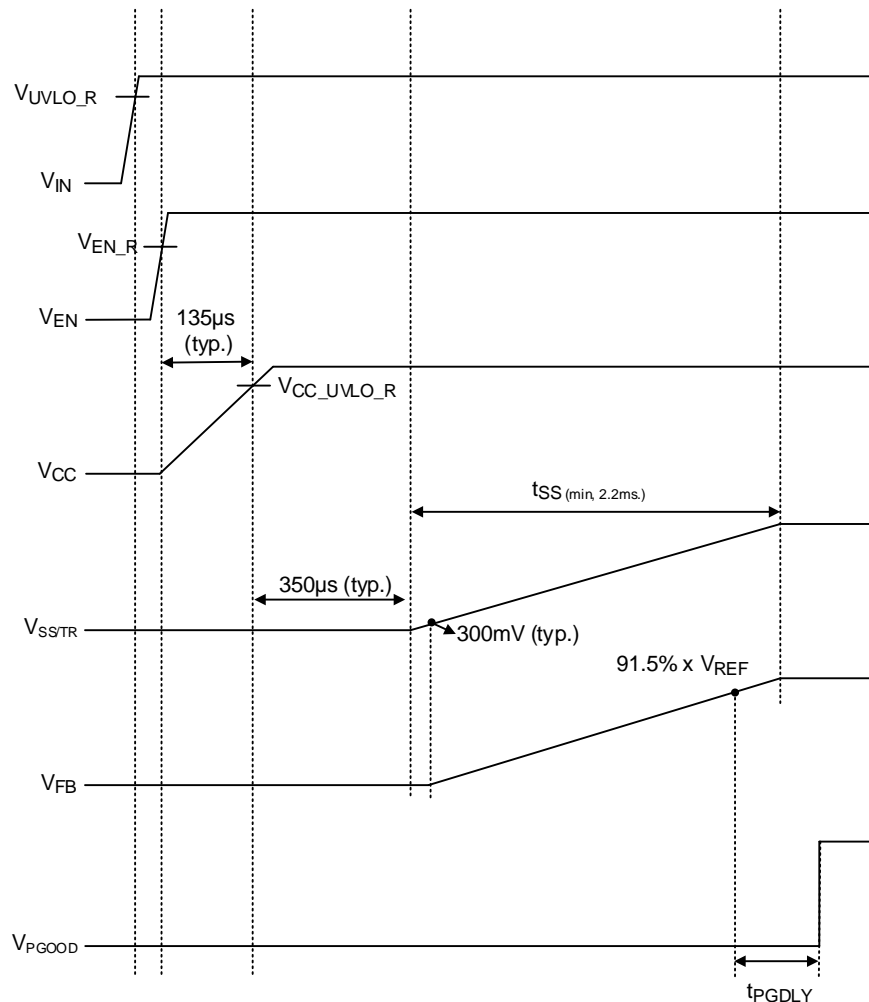

Figure 1. Power-Up Sequence

### 17.3 Output Voltage Tracking and External Reference

The RTQ2806A can replace the internal voltage reference ( $V_{REF}$ ) or track an external power rail by inputting an external voltage signal to the SS/TR pin. The VFB will track this signal, which ranges from 0.3V to 1.4V. During startup, it is essential to ensure that the SS/TR pin voltage reaches 600mV or higher for proper operation.

The Power-Good Output function is activated if  $V_{REF}$  or an external voltage signal exceeds 550mV, and it is disabled if the external voltage signal at the SS/TR pin is lower than 500mV.

### 17.4 Pre-Bias

If there is a residual voltage on the output voltage before startup, both the high-side and low-side MOSFETs are prohibited from switching until the internal soft-start ramp is higher than the feedback voltage. Switching will begin when the soft-start ramp crosses above the feedback voltage and the output voltage will rise from the pre-biased level to its regulated target. Figure 2 shows an example of pre-bias start-up.

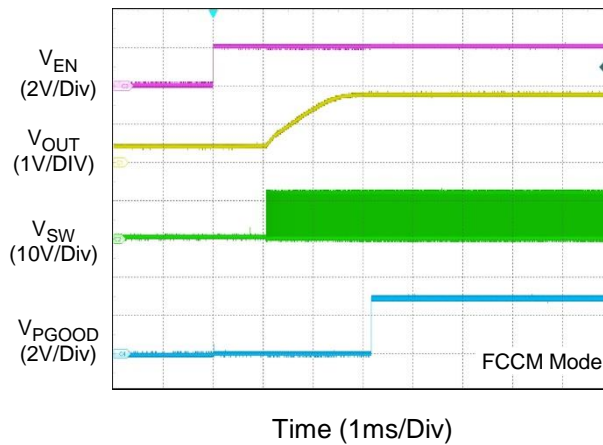
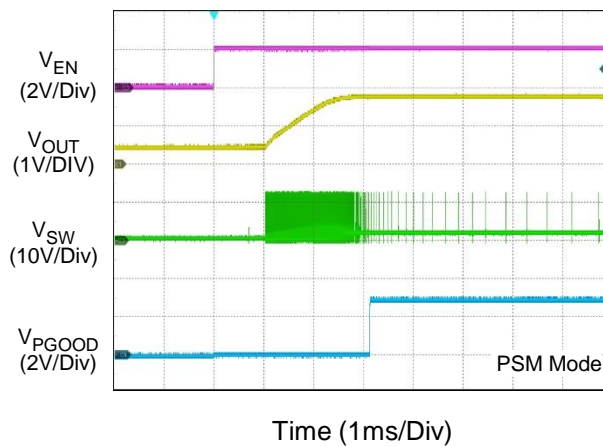

Figure 2. Pre-bias Start-Up

**17.5 Minimum On-Time and Minimum Off-Time**

The constraint on the operating duty cycle is determined by the minimum controllable on-time and off-time. The minimum on-time is the smallest duration of time in which the high-side MOSFET can be in its "ON" state. In continuous mode operation, the effective switching frequency will be decreased to regulate the output voltage target when the minimum on-time limits of a converter are reached. However, reducing the operating frequency will alleviate the constraint on the minimum duty cycle. The equation can be ideally estimated without resistive drop as follows.

$$V_{IN(max)} \leq \frac{V_{OUT}}{f_{SW(max)} \times t_{ON\_MIN(max)}}$$

Where  $t_{ON\_MIN}$  is the minimum on-time, which is 50ns(max).

The minimum off-time,  $t_{OFF\_MIN}$ , is the smallest duration in which the RTQ2806A is capable of turning on the low-side MOSFET, tripping the current comparator, and then turning the power switch back off. The limit on minimum off-time imposes a maximum duty cycle of  $t_{ON}/(t_{ON} + t_{OFF\_MIN})$ .

The calculation for the minimum off-time and the minimum input voltage considering the loss terms is provided below.

$$V_{IN(min)} \geq \left[ \frac{V_{OUT} + I_{OUT\_MAX} \times (R_{DSON\_L} + DCR)}{1 - t_{OFF\_MIN(max)} \times f_{SW(max)}} \right] + I_{OUT\_MAX} \times (R_{DSON\_H} - R_{DSON\_L})$$

where the minimum off-time of the RTQ2806A is 180ns (max);  $R_{DSON\_H}$  is the high-side MOSFET on resistance;  $R_{DSON\_L}$  is the low-side MOSFET on resistance; DCR is the DC resistance of inductor.

**17.6 Mode Selection, Switching Frequency**

The RTQ2806A offers three different switching frequencies of 660kHz, 1100kHz and 2200kHz by setting the MODE pin voltage. The selection of the operating frequency is a tradeoff between efficiency and component size. High-frequency operation allows the use of smaller inductors and capacitor values, while operation at lower frequencies improves efficiency by reducing internal gate charge and transition losses but requires larger inductance values and/or capacitance to maintain low output ripple voltage.

Furthermore, the RTQ2806A can also offer two modes which are force continuous-conduction mode (FCCM) and pulse skipping mode (PSM) for light load conditions to improve efficiency.

When the MODE pin is left floating, the default status will be set to 1100 kHz for PSM operation. Users can configure the mode and operating frequency by connecting a resistor to the AGND pin or VCC pin, as specified in Table 6.

**Table 6. Mode Pin Selection**

Mode Pin Connections	Light Load Mode	Switching Frequency (kHz)
Short to VCC	PSM	1100
243KΩ ±20% to AGND	PSM	2200
121KΩ ±20% to AGND	PSM	660
60.4KΩ ±20% to AGND	FCCM	660
30.1KΩ ±20% to AGND	FCCM	2200
Short to AGND	FCCM	1100

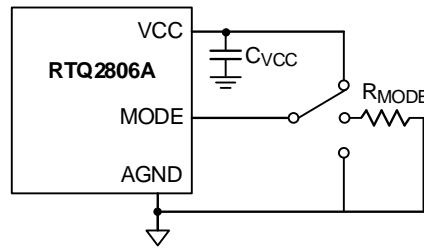

Figure 3. MODE Connection

### 17.7 Light Load Operation

At low load current, the inductor current can drop to zero and become negative. This condition is detected by internal zero current-detect circuitry that utilizes the low-side MOSFET  $R_{DS(on)_L}$  to sense the inductor current. The low-side MOSFET is turned off when the inductor current drops to zero, resulting in pulse skipping mode (PSM). Both power MOSFETs will remain off with the output capacitor supplying the load current until the feedback voltage falls below the internal  $V_{REF}$ . PSM operation maintains high efficiency at light load, while setting MODE to FCCM operation helps meet tight voltage regulation accuracy requirements.

### 17.8 BOOT UVLO

The BOOT UVLO circuit is implemented to ensure a sufficient voltage of BOOT capacitor for turning on the high-side MOSFET at any conditions. The BOOT UVLO usually activates at extremely high conversion ratio or the higher VOUT application operates at very light load. With such conditions when the BOOT to SW voltage falls below  $V_{BOOT\_UVLO\_F}$  (2.3V, typ.), the device turns on the BOOT recharge path (120ns, typ.) to charge the BOOT capacitor.

### 17.9 Power-Good Output

The RTQ2806A features an open-drain power-good indication which is connected to an external voltage source through a pull-up resistor. The power-good function is activated after soft-start is finished and is controlled by the feedback signal  $V_{FB}$ . During soft-start,  $V_{PGOOD}$  is actively held low and only allowed to become high after soft-start is finished. If  $V_{FB}$  rises above the  $V_{TH\_PGLH1}$  (91.5% of the  $V_{REF}$ , typ.), the  $V_{PGOOD}$  pin will be in high impedance and  $V_{PGOOD}$  will be held high after a certain delay elapsed. When  $V_{FB}$  falls below  $V_{TH\_PGLH2}$  (80% of the  $V_{REF}$ , typ.) or exceeds  $V_{TH\_PGHL1}$  (116% of the  $V_{REF}$ , typ.), the  $V_{PGOOD}$  will be pulled low. For  $V_{FB}$  higher than  $V_{TH\_PGHL1}$ ,  $V_{PGOOD}$  can be pulled high again if  $V_{FB}$  drops back to  $V_{TH\_PGLH2}$  (108% of the  $V_{REF}$ , typ.). Once being started-up, if any internal protection is triggered,  $V_{PGOOD}$  will be pulled low to GND. The internal open-drain pull-down device will pull the  $V_{PGOOD}$  low. This is to prevent false flag operation for short excursions in output voltage, such as during line and load transients. The power-good indication profile is shown in Figure 4.

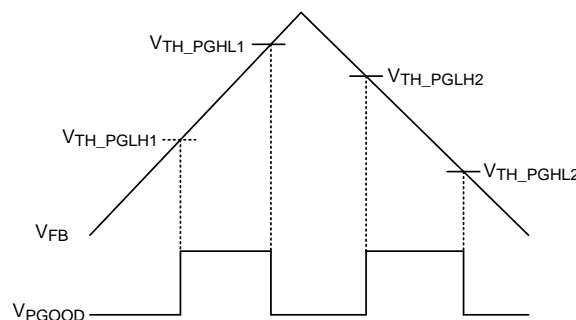

Figure 4. The Logic of PGOOD

**17.10 Overcurrent-limit protection**

The RTQ2806A features cycle-by-cycle current-limit protection on the low-side MOSFETs, and the protection prevents the device from catastrophic damage due to output short circuit, overcurrent, or inductor saturation.

The low-side MOSFET valley current-limit protection, as shown in Figure 5, is achieved by measuring the inductor current through the low-side MOSFET and mirroring to the RLIM pin with the ratio of Gcs using a resistor during the low-side on-time. Once the inductor current rises above the low-side switch valley current-limit threshold (ILIM\_L), the on-time one-shot will be inhibited until the inductor current ramps down to the ILIM\_L; that is, another on-time can only be triggered when the inductor current goes below ILIM\_L.

The RTQ2806A provides a programmable cycle-by-cycle valley current limit for low-side MOSFET switch by RLIM pin. The output current-limit threshold can be calculated as below:

$$R_{LIM}(\Omega) = \frac{V_{LIM}}{G_{CS} \times \left( I_{LIM} - \frac{(V_{IN} - V_{OUT}) \times V_{OUT}}{V_{IN}} \times \frac{1}{2 \times L \times f_{SW}} \right)}$$

Where  $V_{LIM} = 1.2V$ ,  $G_{CS} = 40\mu A/A$ , and  $I_{LIM}$  is the desired output current limit (A).

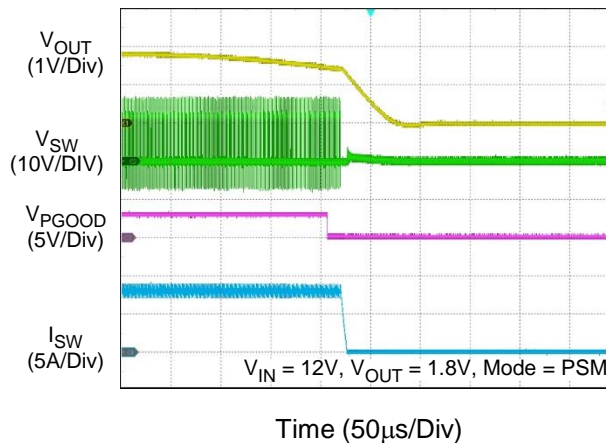

Figure 5. Overcurrent-limit protection

**17.11 Output Undervoltage Protection and Hiccup Mode**

The RTQ2806A includes output undervoltage protection (UVP) against over-load or short-circuited condition by constantly monitoring the feedback voltage, VFB. If VFB drops below the undervoltage protection threshold VUVP (80% of the VREF, typ.), the UV comparator will go high to turn off both the internal high-side and low-side MOSFETs. When the UVP condition remains for a period, a soft-start sequence for auto-recovery will be initiated. If the fault condition is removed, the converter will resume normal operation; otherwise, such cycle for auto-recovery will be repeated until the fault condition is cleared. Hiccup mode allows the circuit to operate safely with low input current and power dissipation. Normal operation resumes as soon as the overload or short-circuit condition is removed. The behavior of UVP and Hiccup mode is shown in Figure 6.

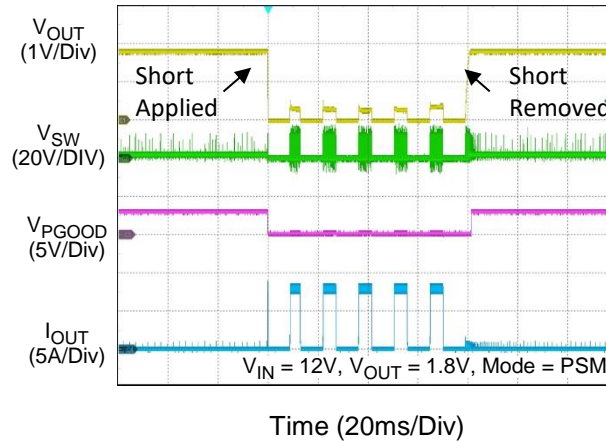

Figure 6. Output Undervoltage Protection and Hiccup mode

**17.12 Negative Current Limit**

The RTQ2806A also monitors inductor current during the "ON" state of the low-side MOSFET to prevent too large negative current flowing through the low-side MOSFET. Once the negative current exceeds the low-side switch negative current-limit threshold  $I_{LIM\_NEG}$  ( $-8A$ , typ.), the device turns off the low-side MOSFET for 700ns. This behavior can keep the valley of negative current at  $I_{LIM\_NEG}$  to protect low-side MOSFET. Designer should choose appropriate inductance to avoid triggering  $I_{LIM\_NEG}$  during normal operation.

**17.13 Output Overvoltage Protection**

The RTQ2806A includes an output overvoltage protection (OVP) circuit to limit output voltage and minimize output voltage overshoot, as shown in Figure 7. If the  $V_{FB}$  goes above the 116% of the  $V_{REF}$ , after the 15 $\mu$ s OVP de-glitch time, the PGOOD pin remains low until the overvoltage condition is cleared. If the overvoltage condition still exists, the low-side MOSFET remains on until the low-side switch valley current reaches the negative current limit ( $I_{LIM\_NEG}$ ). Once reaching the  $I_{LIM\_NEG}$  the low-side MOSFET is turned off temporarily around 700ns before it is turned on again.

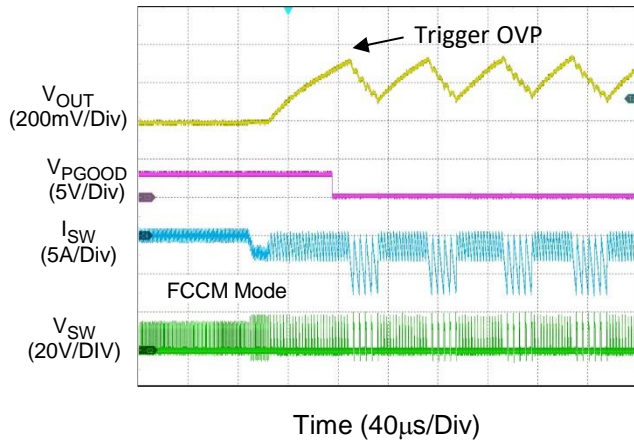
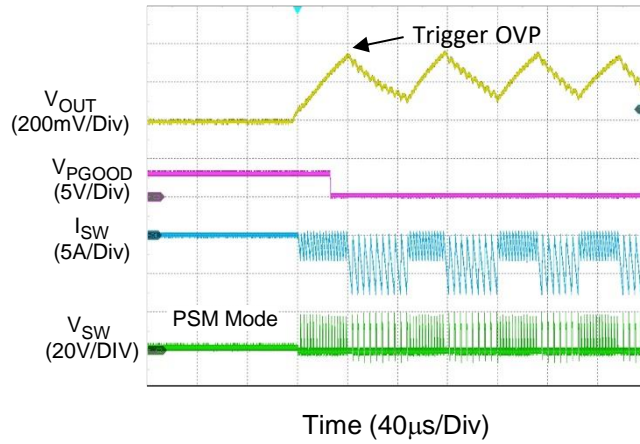

Figure 7. Output Overvoltage Protection



### 17.14 Output Quick Discharge Mode

The RTQ2806A features Output Quick Discharge Mode (OQDM) to mitigate overshoot before triggering the OVP. When the  $V_{FB}$  voltage exceeds 104% of the  $V_{REF}$  but remains below the OVP threshold (typically 116%), OQDM is activated, the behavior as shown in Figure 8. During OQDM, the high-side MOSFET is off, while the low-side MOSFET remains on until inductor current reaches  $-4A$  (typ.) or the  $V_{FB}$  voltage falls below 102%. Once the inductor current reaches  $-4A$ , the low-side MOSFET is briefly turned off for 700ns before being turned on again. This sequence is repeated until the  $V_{FB}$  voltage falls below 102% of the  $V_{REF}$ . After completing 15 consecutive FCCM cycles, the RTQ2806A exits the OQDM. This mode effectively reduces overshoot and ensures stable operation.

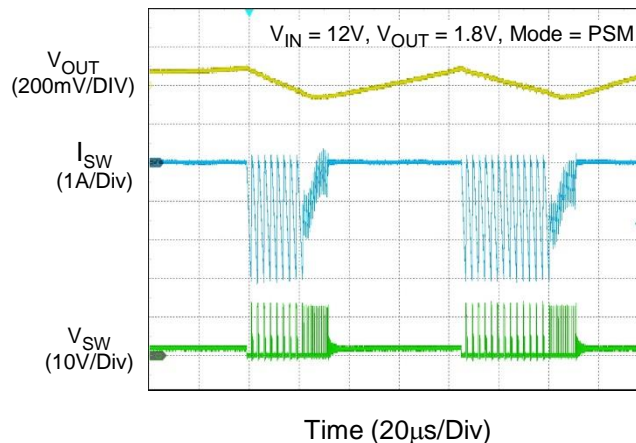

Figure 8. Output Quick Discharge Mode

### 17.15 Output Voltage Discharge

When the RTQ2806A is disabled by EN pin, UVLO or OTP, the device discharges the output capacitors (via SW pins) through an internal discharge resistor ( $80\Omega$ , typ.) connected to ground. This function prevents the reverse current from flowing the output capacitors to the input capacitors once the input voltage collapses. It does not need to rely on another active discharge circuit for discharging output capacitors. This function will be turned off when the fault condition is removed.

### 17.16 Over-Temperature Protection (OTP)

The RTQ2806A includes an over-temperature protection (OTP) circuitry to prevent overheating due to excessive power dissipation. The OTP will shut down switching operation when junction temperature exceeds the over-temperature protection threshold  $T_{OTP}$  ( $160^{\circ}C$ , typ.). Once the junction temperature cools down by the over-temperature protection hysteresis  $T_{OTP\_HYS}$  ( $20^{\circ}C$ , typ.), the RTQ2806A will resume normal operation with a complete soft-start. Note that the over-temperature protection is intended to protect the device during momentary overload conditions. The protection is activated outside of the absolute maximum range of operation as a secondary fail-safe and therefore should not be relied upon operationally. Continuous operation above the specified absolute maximum operating junction temperature may impair device reliability or permanently damage the device.



## 18 Application Information

*Richtek's component specification does not include the following information in the Application Information section. Thereby no warranty is given regarding its validity and accuracy. Customers should take responsibility to verify their own designs and reserve suitable design margin to ensure the functional suitability of their components and systems.*

A general RTQ2806A application circuit is shown in a typical application circuit section. External component selection is largely driven by the load requirement. Next, the inductor L is chosen and then the input capacitor C<sub>IN</sub>, the output capacitor C<sub>OUT</sub>, the internal regulator capacitor C<sub>VCC</sub>, and the bootstrap capacitor C<sub>BOOT</sub>, can be selected. Next, feedback resistors are selected to set the desired output voltage. Finally, the remaining optional external components can be selected for functions such as the EN operation voltage determined by the V<sub>IN</sub> divider, the operation frequency, the operation at light load, valley current limit value, external soft-start time, and Power-Good function.

### 18.1 Switching Frequency and MODE Selection

The switching frequency, current limit, and switching mode (PSM or FCCM) are set by a voltage divider connected solely from VCC to GND to the MODE pin.

The selection of the switching frequency is a trade-off between efficiency and system component size. High-frequency operation allows the use of smaller inductor and capacitor values. Operating at lower frequencies improves efficiency by reducing internal gate charge and transition losses but requires larger inductance values and/or capacitance to maintain low output ripple voltage.

### 18.2 Inductor Selection

The inductor selection makes trade-offs among size, cost, efficiency, and transient response requirements. Generally, three key inductor parameters are specified for operation with the device: inductance value (L), inductor saturation current (I<sub>SAT</sub>), and DC resistance (DCR).

A good compromise between size and loss is a 30% peak-to-peak ripple current ΔI<sub>L</sub> to the IC rated current. The switching frequency, input voltage, output voltage, and selected inductor ripple current determines the inductor value as follows:

$$L = \frac{V_{OUT} \times (V_{IN} - V_{OUT})}{V_{IN} \times f_{SW} \times \Delta I_L}$$

Larger inductance values result in lower output ripple voltage and higher efficiency, but a slightly degrade transient response. Lower inductance values allow for smaller case size, but the increased ripple lowers the effective current-limit threshold and increases the AC losses in the inductor. To enhance efficiency, choose a low-loss inductor with the lowest possible DC resistance that fits in the allotted dimensions. The inductor value determines the ripple current and the load-current value at which the boundary of PSM and FCCM switchover occurs.

The selected inductor must require a enough saturate current rating above the peak inductor current before saturation. The peak inductor current (I<sub>L\_PEAK</sub>) is estimated as below.

$$\Delta I_L = \frac{V_{OUT} \times (V_{IN} - V_{OUT})}{V_{IN} \times f_{SW} \times L}$$

$$I_{L\_PEAK} = I_{OUT\_MAX} + \frac{1}{2} \Delta I_L$$

The current flowing through the inductor is the inductor ripple current plus the output current. During power up,

faults, or transient load conditions, the inductor current can increase above the peak inductor current level calculated above. In transient conditions, the inductor current can increase up to the switch current limit of the device. For this reason, the most conservative approach is to specify an inductor with a saturation current rating equal to or greater than the switch current limit rather than the peak inductor current.

The reverse inductor current should be considered. In FCCM operation, the design of inductor valley current should be higher than -4A to prevent triggering Output Quick Discharge Mode value at no load operation.

**18.3 Input Capacitor Selection**

Input capacitance, C<sub>IN</sub>, is needed to filter the pulsating current at the drain of the high-side power MOSFET. The C<sub>IN</sub> should be sized to do this without causing a large variation in input voltage. The peak-to-peak voltage ripple on input capacitor can be estimated as the equation below:

$$\Delta V_{CIN} = D \times I_{OUT} \times \frac{1-D}{C_{IN} \times f_{SW}} + I_{OUT} \times ESR$$

where

$$D = \frac{V_{OUT}}{V_{IN} \times \eta}$$

Figure 9 shows the C<sub>IN</sub> ripple current flowing through the input capacitors and the resulting voltage ripple across the capacitors.

The equivalent series resistance (ESR) is very low for ceramic capacitors. The ripple caused by ESR can be ignored, and the minimum input capacitance can be estimated as the equation below:

$$C_{IN\_MIN} = I_{OUT\_MAX} \times \frac{D(1-D)}{\Delta V_{CIN\_MAX} \times f_{SW}}$$

where ΔV<sub>CIN\_MAX</sub> = 200mV for typical application (V<sub>IN</sub> > 7V)

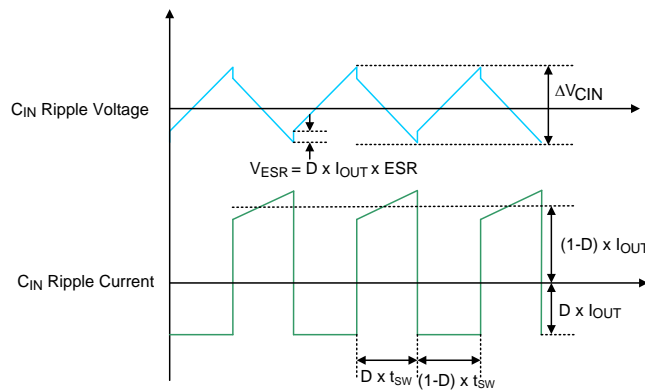

Figure 9. C<sub>IN</sub> Ripple Voltage and Ripple Current

In addition, the input capacitor needs to have a very low ESR and must be rated to handle the worst-case RMS input current of: The RMS ripple current (I<sub>RMS</sub>) of the converter can be determined by the input voltage (V<sub>IN</sub>), output voltage (V<sub>OUT</sub>), and rated output current (I<sub>OUT</sub>) as the following equation:

$$I_{RMS} \cong I_{OUT\_MAX} \times \frac{V_{OUT}}{V_{IN}} \times \sqrt{\frac{V_{IN}}{V_{OUT}} - 1}$$

From the above, the maximum RMS input ripple current occurs at maximum output load, which should be considered when evaluating the current capabilities of the input capacitors. The maximum ripple voltage usually

occurs at 50% duty cycle, that is,  $V_{IN} = 2 \times V_{OUT}$ . It is common to use the worse  $I_{RMS} \cong 0.5 \times I_{OUT\_MAX}$  at  $V_{IN} = 2 \times V_{OUT}$  for design. Note that ripple current ratings from capacitor manufacturers are often based on only 2000 hours of life which makes it advisable to further de-rate the capacitor, or choose a capacitor rated at a higher temperature than required.

Several capacitors may also be paralleled to meet size, height and thermal requirements in the design. For low input voltage applications, sufficient bulk input capacitance is needed to minimize transient effects during output load changes.

Ceramic capacitors are ideal for switching regulator applications because its small size, robustness and very low ESR. However, care must be taken when these capacitors are used at the input. A ceramic input capacitor combined with trace or cable inductance forms a high quality (under damped) tank circuit. If the RTQ2806A circuit is plugged into a live supply, the input voltage can ring to twice its nominal value, possibly exceeding the device's rating. This situation is easily avoided by placing the low ESR ceramic input capacitor in parallel with a bulk capacitor with higher ESR to damp the voltage ringing.

The input capacitor should be placed as close as possible to the  $V_{IN}$  pins, with a low inductance connection to the PGND of the IC. In addition to a larger bulk capacitor, one small ceramic capacitor of  $0.1 \mu F$  should be placed close to the part. The capacitors should be 0402 or 0603 in size. X7R capacitors are recommended for best performance across temperature and input voltage variations.

**18.4 Output Capacitor Selection**

The selection of  $C_{OUT}$  is determined by considering to satisfy the voltage ripple, the transient loads and to ensure that control loop is stable. Loop stability can be checked by viewing the load transient response. The peak-to-peak output ripple,  $\Delta V_{OUT}$ , is characterized by two components, which are ESR ripple  $\Delta V_{P-P\_ESR}$  and capacitive ripple  $\Delta V_{P-P\_C}$ , and can be expressed as below:

$$\Delta V_{OUT} = \Delta V_{P-P\_ESR} + \Delta V_{P-P\_C}$$

$$\Delta V_{P-P\_ESR} = \Delta I_L \times R_{ESR}$$

$$\Delta V_{P-P\_C} = \frac{\Delta I_L}{8 \times C_{OUT} \times f_{SW}}$$

Where the  $\Delta I_L$  is the peak-to-peak inductor ripple current and  $R_{ESR}$  is the equivalent series resistance of  $C_{OUT}$ . The highest output ripple is at maximum input voltage since  $\Delta I_L$  increases with input voltage. Multiple capacitors placed in parallel may be needed to meet the ESR and RMS current handling requirements.

Regarding to the transient loads, the  $V_{SAG}$  and  $V_{SOAR}$  requirement should be taken into consideration for choosing the output capacitance value. The amount of output sag is a function of the maximum duty factor, which can be calculated from the on-time and minimum off-time.

$$t_{ON} = \frac{V_{OUT}}{V_{IN} \times f_{SW}}$$

$$D_{MAX} = \frac{t_{ON}}{t_{ON} + t_{OFF\_MIN}}$$

The worst-case output sag voltage can be determined by:

$$\Delta V_{OUT\_SAG} = \frac{L \times (I_{L\_PEAK})^2}{2 \times C_{OUT} \times (V_{IN} \times D_{MAX} - V_{OUT})}$$

The amount of overshoot due to stored inductor energy when the load is removed can be calculated as:

$$\Delta V_{OUT\_SOAR} = \frac{L \times (I_{L\_PEAK})^2}{2 \times C_{OUT} \times V_{OUT}}$$

Ceramic capacitors have very low equivalent series resistance (ESR) and provide the best ripple performance. Be careful to consider the voltage coefficient of ceramic capacitors when choosing the value and case size. Most ceramic capacitors lose 50% or more of their rated value when used near their rated voltage.

### 18.5 Internal VCC Regulator

Good bypassing at VCC pin is necessary to supply the high transient currents required by the power MOSFET gate drivers. Place a low ESR MLCC capacitor with capacitance  $\geq 1\mu\text{F}$  as close as possible to VCC pin, and the rated voltage of  $C_{VCC}$  is at least 6.3V or higher to minimize DC bias derating, using 0603 or 0805 in size is recommend.

Applications with high input voltage and high switching frequency will increase die temperature because of the higher power dissipation across the LDO. Do not connect VCC to provide power to other devices or loads.

### 18.6 Bootstrap Driver Supply

The bootstrap capacitor ( $C_{BOOT}$ ) between the BOOT pin and the SW pin is used to create a voltage rail above the applied input voltage,  $V_{IN}$ . Specifically, the bootstrap capacitor is charged through an internal MOSFET switch to a voltage equal to approximately  $V_{VCC}$  each time the LSFET is turned on. The charge on this capacitor is then used to supply the required current during the remainder of the switching cycle.

The selection of  $C_{BOOT}$  considers the voltage variation allowed on the high-side MOSFET driver after turn-on. Choose  $\Delta V_{BOOT}$  such that the available gate-drive voltage is not significantly degraded when determining  $C_{BOOT}$ . A typical range of  $\Delta V_{BOOT}$  is from 100mV to 300mV. The bootstrap capacitor should be a low-ESR ceramic capacitor. For most applications, a  $0.1\mu\text{F}$  ceramic capacitor with X5R or better grade dielectric is recommended. The capacitor should have a 10V or higher voltage rating.

EMI issue is worse when the switch is turned on rapidly due to high di/dt noises. In some cases, it is desirable to reduce EMI further, even at the expense of some additional power dissipation. The turn-on rate of the high-side switch can be slowed by placing a small ( $< 10\Omega$ ) resistor between the BOOT pin and the external bootstrap capacitor. This will slow down the rates of the high-side switch turn-on and the rise of  $V_{SW}$ . The recommended application circuit is shown in Figure 10, which includes an external bootstrap diode for charging the bootstrap capacitor and a bootstrap resistor  $R_{BOOT}$  placed between the BOOT pin and the capacitor connection.

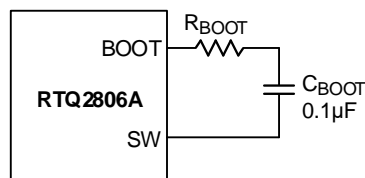

Figure 10. External Bootstrap Resistor at the BOOT Pin

### 18.7 Output Voltage Programming

The output voltage can be programmed by a resistive divider from the output to ground with the midpoint connected to the FB pin. The resistive divider allows the FB pin to sense a fraction of the output voltage as shown in Figure 11 and the output voltage is set according to the following equation:

$$V_{OUT} = V_{REF} \times \left( 1 + \frac{R1}{R2} \right)$$

where the reference voltage  $V_{REF}$ , is typically 0.6V.

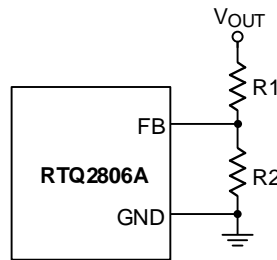

Figure 11. Output Voltage Setting

The recommended resistance of R2 is 10kΩ, ranging from 1kΩ to 10kΩ for good noise immunity consideration. The resistance of R1 can then be obtained as below:

$$R1 = \frac{R2 \times (V_{OUT} - V_{REF})}{V_{REF}}$$

For better output voltage accuracy, the divider resistors (R1 and R2) with ±1% tolerance or better should be used. The placement of the resistive divider should be very close to the FB pin to minimize PCB trace length and noise immunity consideration. Furthermore, great care should be taken to route the feedback trace away from noise sources, such as the inductor or the SW trace.

### 18.8 Feedforward Capacitor (CFF)

The RTQ2806A is optimized for low duty-cycle applications and the control loop is stable with low ESR ceramic output capacitors. In higher duty-cycle applications (higher output voltages or lower input voltage), the internal ripple signal will increase in amplitude. Before the ACOT® control loop can react to an output voltage fluctuation, the voltage change on the feedback signal must exceed the internal ripple amplitude. Because of the large internal ripple in this condition, the response may become too slow, and may show an under-damped response. This can cause some ringing in the output, and is especially visible at higher output voltage applications like 12V to 5V where duty-cycle is high and the feedback network attenuation is large, adding to the delay. As shown in Figure 12, adding a feedforward capacitor (CFF) across the upper feedback resistor is recommended. This increases the damping of the control system.

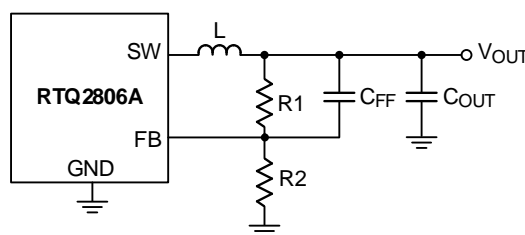

Figure 12. Feedback Loop with Feedforward Capacitor

Loop stability can be checked by viewing the load transient response. A load step with a speed that exceeds the converter bandwidth must be applied. For ACOT®, loop bandwidth can be in the order of 100 to 200kHz, so a load step with 500ns maximum rise time ( $di/dt \approx 2A/\mu s$ ) ensures the excitation frequency is sufficient. It is important that the converter operates in PWM mode, outside the light load efficiency range, and below any current-limit threshold. A load transient from 30% to 60% of maximum load is reasonable which is shown in Figure 13.

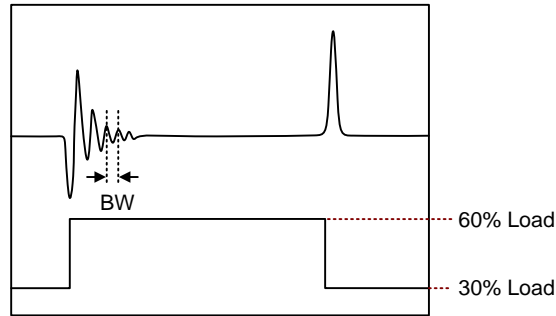

Figure 13. Example of Measuring the Converter BW by Fast Load Transient

C<sub>FF</sub> can be calculated basing on below equation:

$$C_{FF} = \frac{1}{2\pi \times BW} \times \sqrt{\frac{1}{R1} \times \left( \frac{1}{R1} + \frac{1}{R2} \right)}$$

Figure 14. shows the transient performance with and without feedforward capacitor.

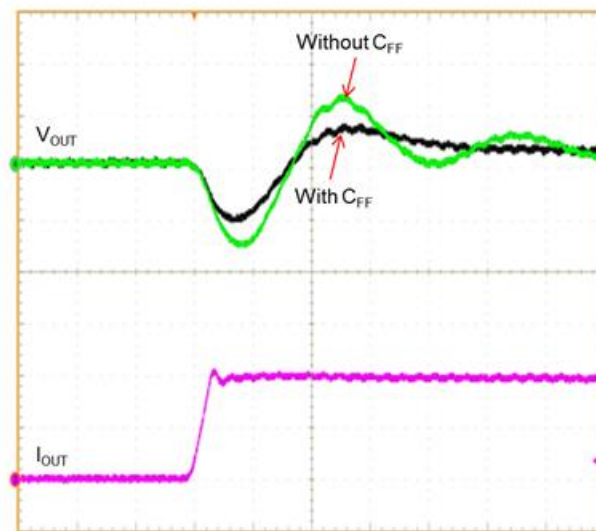

Figure 14. Load Transient Response with and without Feedforward Capacitor

Note that, after defining the C<sub>FF</sub>, please also check the load regulation because feedforward capacitor might inject an offset voltage into V<sub>OUT</sub> to cause V<sub>OUT</sub> inaccuracy. If the output voltage is over specification caused by calculated C<sub>FF</sub>, please decrease the value of feedforward capacitor C<sub>FF</sub>.

**18.9 Enable and Adjustable UVLO**

The EN pin controls the turn-on and turn-off of the device. When EN pin voltage is above the turn-on threshold (V<sub>EN\_R</sub>), the device starts switching. It stops switching when the EN pin voltage falls below the turn-off threshold (V<sub>EN\_F</sub>). The RTQ2806A internally weekly pull-down the EN pin. For automatic start-up, the EN pin can be connected to the input supply V<sub>IN</sub> directly through a pull-up resistor R<sub>EN</sub>. The large built-in hysteresis band makes the EN pin useful for simple delay and timing circuits. The EN pin can be externally connected to V<sub>IN</sub> by adding a resistor R<sub>EN</sub> and a capacitor C<sub>EN</sub>, as shown in Figure 15, to have an additional delay.

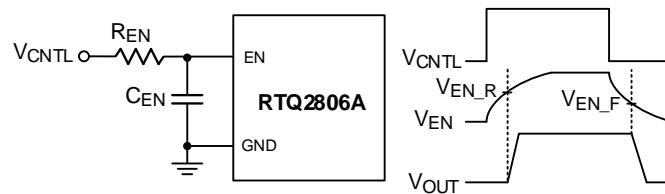

Figure 15. Enable Timing Control

An external MOSFET can be added for the EN pin to be logic-controlled, as shown in Figure 16. In this case, a pull-up resistor, REN, is connected between Vcntl and the EN pin. The MOSFET Q1 will be under logic control to pull down the EN pin.

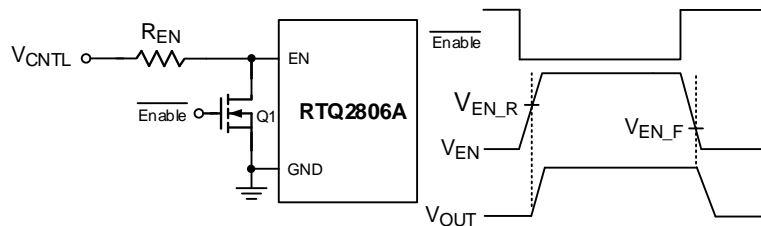

Figure 16. Logic Control for the EN Pin

If the device is desired to enable under specific VIN or be shut down, a resistive divider (REN1 and REN2) can be used to externally set the input VULO threshold as shown in Figure 17.

To set the start voltage, first select the bottom resistor REN2, the recommended value is between 10kΩ and 100kΩ.

A resistive divider between VIN and EN can set a different turn-on (VSTART) or turn-off thresholds (VSTOP).

This is recommended for customer design when without additional EN logic signal, to avoid bouncing occurring at the EN pin.

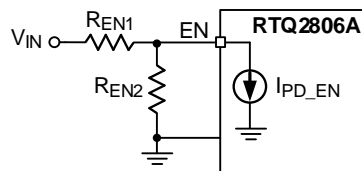

Figure 17. Resistor Divider for Lockout Threshold Setting

$$R_{EN1} = \frac{(V_{START} - V_{EN\_R})}{I_{PD\_EN} + \frac{V_{EN\_R}}{R_{EN2}}}$$

$$V_{START} = V_{EN\_R} \times \frac{R_{EN1} + R_{EN2}}{R_{EN2}}$$

$$V_{STOP} = V_{EN\_F} \times \frac{R_{EN1} + R_{EN2}}{R_{EN2}}$$

## 18.10 Thermal Considerations

Thermal Considerations In many applications, the RTQ2806A does not generate much heat due to its high efficiency and low thermal resistance of its thermally enhanced WQFN-14L 2x3 (FC) package. However, in applications where the RTQ2806A is running at a high ambient temperature, high input voltage, and high switching frequency, the generated heat may exceed the maximum junction temperature of the part. To avoid permanent damage to the device, the junction temperature should never exceed the maximum junction temperature listed under Absolute Maximum Ratings. If the junction temperature reaches approximately 160°C, the RTQ2806A will stop switching the power MOSFETs until the temperature drops by about 20°C cooler. The maximum power dissipation can be calculated by the following formula:

$$P_{D(MAX)} = (T_{J(MAX)} - T_A) / \theta_{JA(EFFECTIVE)}$$

Where

- $T_{J(MAX)}$  is the maximum allowed junction temperature of the die. For recommended operating condition specifications, the maximum junction temperature is 150°C.
- $T_A$  is the ambient operating temperature,  $\theta_{JA(EFFECTIVE)}$  is the system-level junction to ambient thermal resistance. It can be estimated from thermal modeling or measurements in the system.

The thermal resistance of the device strongly depends on the surrounding PCB layout and can be enhanced by incorporating a copper ground heat sink. Additionally, including backside copper with thermal vias, stiffeners, and other enhancements can help reduce thermal resistance.

Experiments in the Richtek thermal lab show that simply set  $\theta_{JA(EFFECTIVE)}$  as 110% to 120% of the  $\theta_{JA}$  is reasonable to obtain the allowed  $P_{D(MAX)}$ .

the simulated thermal resistance of the RTQ2806A when mounted on PCBs with varying stack-up and copper thickness. The thermal model layout is based on the RTQ2806A evaluation board.

Table 7. shows the simulated thermal resistance of the RTQ2806A when mounted on PCBs with varying stack-up and copper thickness. The thermal model layout is based on the RTQ2806A evaluation board.

**Table 7. Simulated Thermal Resistance with Difference Tack-Up and Copper Thickness**

Simulated $\theta_{JA}$	$\theta_{JA(EFFECTIVE)}$ (°C/W)
4 Layer with 2oz copper	37.88 * 1.1

As an example, consider the case when the RTQ2806A is used in applications where  $V_{IN} = 12V$ ,  $I_{OUT} = 6A$ ,  $V_{OUT} = 1.8V$ .

The efficiency at 1.8V, 6A is 88.3% by using WE-74437346010 (1μH, 10mΩ DCR) as the inductor and measured at room temperature. The AC core loss of inductance is 34.9mW can be obtained from its website. In this case, the power dissipation of RTQ2806A is

$$P_{D,RT} = \frac{1-\eta}{\eta} \times P_{OUT} - (I_{OUT}^2 \times DCR + P_{CORE\_AC}) = 1.035W$$

Considering the  $\theta_{JA(EFFECTIVE)}$  is 41.67°C/W by using RTQ2806A evaluation board with 4 layers PCB and 2oz copper thickness, the junction temperature of the regulator operating in a 25°C ambient temperature is approximately:

$$T_J = 68^\circ C$$



**18.11 Layout Guidelines**

When laying out the printed circuit board, the following checklist should be used to ensure proper operation of the RTQ2806A:

- ▶ Use a four-layer or six-layer PCB with a maximum ground plane for optimal thermal performance.
- ▶ Place input capacitors as close to the VIN pins as possible.
- ▶ Place input MLCC capacitors as close to the VIN and PGND pins as possible. It is highly recommended to use a 0.1μF/0402 ceramic capacitor between the VIN pin 3 and PGND pin 1.
- ▶ Place the VCC decoupling capacitor, C<sub>VCC</sub>, as close to the VCC pin as possible.
- ▶ Place the bootstrap capacitor, C<sub>BOOT</sub>, as close to the IC as possible. A 0.1μF to 1μF with 10V or higher rating is recommended for the bootstrap capacitor.
- ▶ Place multiple vias under the device near VIN and PGND, and place near input capacitors to reduce parasitic inductance and improve thermal performance. To keep thermal resistance low, extend the ground plane as much as possible, and adds thermal vias under and near the RTQ2806A to additional ground planes within the circuit board and on the bottom side.
- ▶ The high frequency switching nodes, SW and BOOT, should be as small as possible. Keep analog components away from the SW and BOOT nodes.
- ▶ Place capacitors C<sub>SS</sub> as close to the SS/TR as possible.
- ▶ Connect the feedback sense network behind via of the output capacitor.
- ▶ Place the feedback components R<sub>1</sub>/R<sub>2</sub>/C<sub>FF</sub> near the IC.
- ▶ The ground connection between the analog ground and power ground should be close to IC to minimize the ground current loops. If there is only one ground plane, it should keep enough isolation between analog return signals and high-power signals.

Figure 18 is the layout example which uses (92mm x81mm), four-layer PCB with 2oz copper.



**19 Outline Dimension**

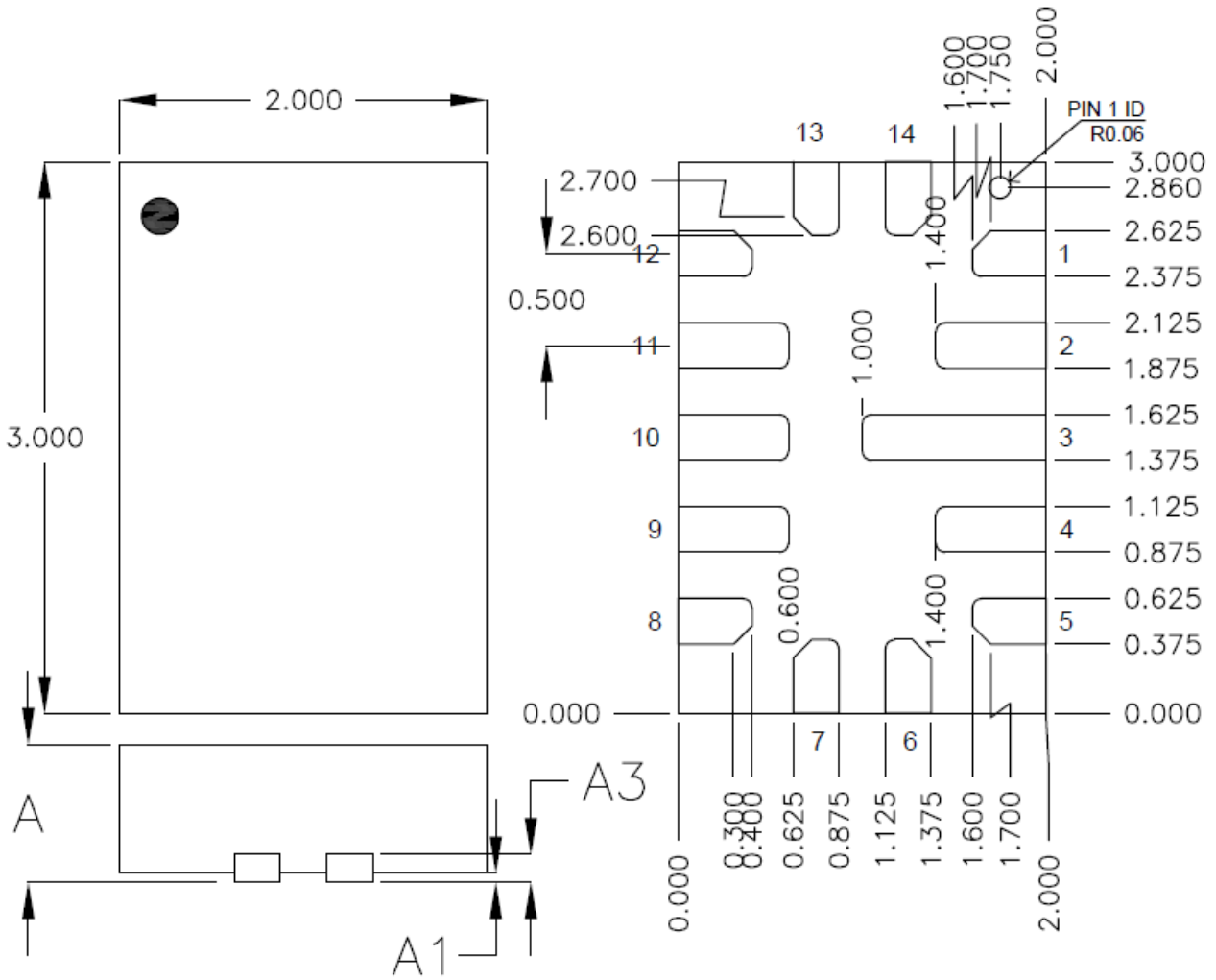

Symbol	Dimensions In Millimeters		Dimensions In Inches	
	Min	Max	Min	Max
A	0.700	0.800	0.028	0.031
A1	0.000	0.050	0.000	0.002
A3	0.175	0.250	0.007	0.010

Tolerance
±0.050

**W-Type 14T QFN 2x3 Package (FC)**



**21 Packing Information**

**21.1 Tape and Reel Data**

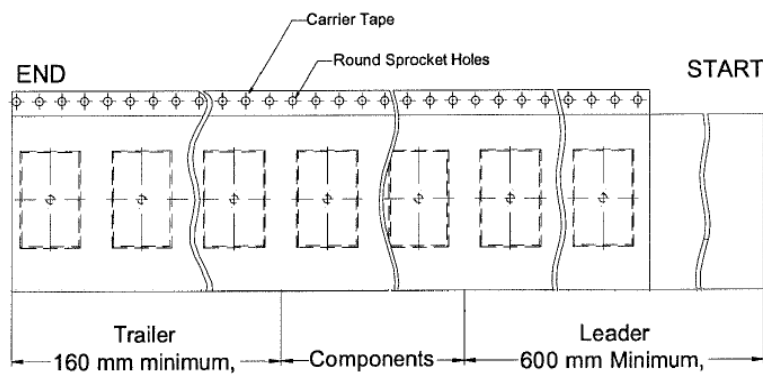
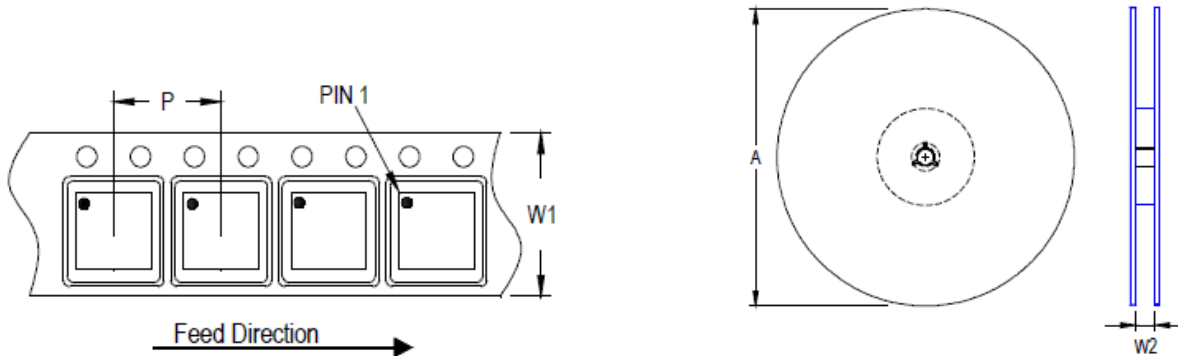



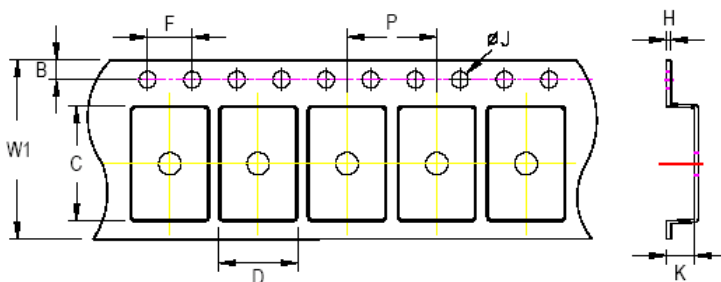



Package Type	Tape Size (W1) (mm)	Pocket Pitch (P) (mm)	Reel Size (A)		Units per Reel	Trailer (mm)	Leader (mm)	Reel Width (W2) Min./Max. (mm)
			(mm)	(in)				
QFN/DFN 2x3	12	8	180	7	1,500	160	600	12.4/14.4



**C, D, and K are determined by component size. The clearance between the components and the cavity is as follows:**  
**- For 12mm carrier tape: 0.5mm max.**

Tape Size	W1		P		B		F		ØJ		H
	Max.	Min.	Max.	Min.	Min.	Max.	Min.	Max.	Min.	Max.	Max.
12mm	12.3mm	7.9mm	8.1mm	1.65mm	1.85mm	3.9mm	4.1mm	1.5mm	1.6mm	0.6mm	

## 21.2 Tape and Reel Packing

Step	Photo/Description	Step	Photo/Description
1	 <p>Reel 7"</p>	4	 <p>3 reels per inner box <b>Box A</b></p>
2	 <p>HIC &amp; Desiccant (1 Unit) inside</p>	5	 <p>12 inner boxes per outer box</p>
3	 <p>Caution label is on backside of Al bag</p>	6	 <p>Outer box <b>Carton A</b></p>

Container Package	Reel		Box				Carton			
	Size	Units	Item	Size(cm)	Reels	Units	Item	Size(cm)	Boxes	Unit
QFN & DFN 2x3	7"	1,500	Box A	18.3*18.3*8.0	3	4,500	Carton A	38.3*27.2*38.3	12	54,000
			Box E	18.6*18.6*3.5	1	1,500	For Combined or Partial Reel.			

**21.3 Packing Material Anti-ESD Property**

Surface Resistance	Aluminum Bag	Reel	Cover tape	Carrier tape	Tube	Protection Band
$\Omega/\text{cm}^2$	$10^4$ to $10^{11}$	$10^4$ to $10^{11}$	$10^4$ to $10^{11}$	$10^4$ to $10^{11}$	$10^4$ to $10^{11}$	$10^4$ to $10^{11}$

**Richtek Technology Corporation**

14F, No. 8, Tai Yuen 1<sup>st</sup> Street, Chupei City

Hsinchu, Taiwan, R.O.C.

Tel: (8863)5526789

Richtek products are sold by description only. Richtek reserves the right to change the circuitry and/or specifications without notice at any time. Customers should obtain the latest relevant information and data sheets before placing orders and should verify that such information is current and complete. Richtek cannot assume responsibility for use of any circuitry other than circuitry entirely embodied in a Richtek product. Information furnished by Richtek is believed to be accurate and reliable. However, no responsibility is assumed by Richtek or its subsidiaries for its use; nor for any infringements of patents or other rights of third parties which may result from its use. No license is granted by implication or otherwise under any patent or patent rights of Richtek or its subsidiaries.

Copyright © 2024 Richtek Technology Corporation. All rights reserved. **RICHTEK** is a registered trademark of Richtek Technology Corporation.



## Datasheet Revision History

Version	Date	Description	Item
00	2024/3/5	Final	