

2x20W, Inductor-Less I²S-input, Low Noise, High-Efficiency Closed-Loop General-Purpose Class-D Digital Audio Amplifier with DRC Control

General Description

The RT9120M is a high efficiency, I²S-input, stereo channel audio power amplifier delivering 2x20W into 8Ω BTL speaker loads. It can deliver over 92% power efficiency and eliminate the need for heat-sink.

The built-in anti-pop functions can reduce the speaker's pop noise under all kind of scenarios. Built-in protection circuits can provide over-temperature, overcurrent, overvoltage, and undervoltage protections and report error status.

The RT9120M is a 3-wired device receiving all clocks from external sources with standard I²S, Left-justified, Right-justified and TDM formats. It can support both master and slave mode with wide input sampling rate from 8kHz to 192kHz. A fully programmable data path routes these channels to the internal speaker drivers.

The RT9120M features one band DRC and flexible input mixer, and power limiting.

Ordering Information

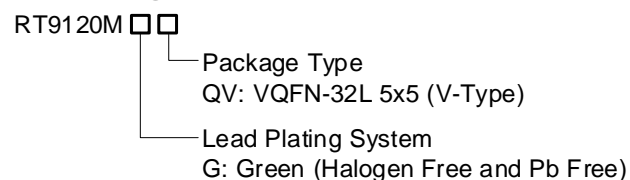

Note:

Richtek products are:

- ▶ RoHS compliant and compatible with the current requirements of IPC/JEDEC J-STD-020.
- ▶ Suitable for use in SnPb or Pb-free soldering processes.

Features

- **Wide Input Supply Range: 4.5V to 26.4V**
- **Support 1.8V, 3.3V I/O**
- **I²S, LJ, RJ, TDM Digital Audio Interface**
- **2x20W at into 8Ω BTL at 20V**
- **2x9W at into 8Ω BTL at 12V**
- **SNR Up to 108dB**
- **THD + N is 0.03% at 1W**
- **45μV Noise Floor**
- **Efficiency Up to 92% at 2x10W for 8Ω**
- **Sampling Frequency from 8kHz to 192kHz**
- **Built-In Anti-Pop Function for BTL BD Modulations**
- **Flexible Input Mixer**
- **Programmable Coefficients for DRC Filters and Supporting Multi-Compression Ratios**
- **Built-In DC Blocking Filters**
- **Built-in Thermal Fold Back Control**
- **Protection Features: UVLO, OVP, OCP, OTP and DCP**
- **Filter-Less Application**
- **VQFN-32L Thermally-Enhanced Package**
- **RoHS Compliant and Halogen Free**

Applications

- LCD-TV
- Monitors
- Home Audio
- Amusement Equipment
- Electronic Music Equipment

Marking Information

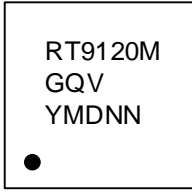

RT9120MGQV: Product Number
YMDNN: Date Code

Pin Configuration

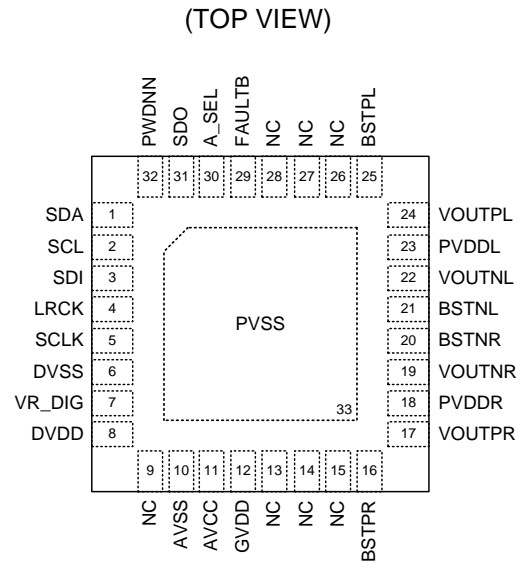

VQFN-32L 5x5

Simplified Application Circuit

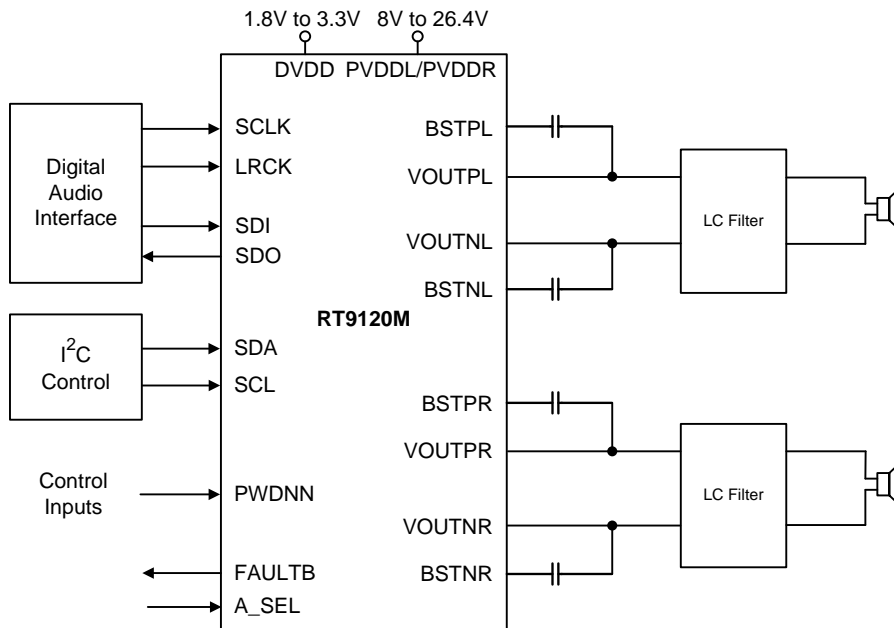

Functional Pin Description

Pin No.	Pin Name	IO	Pin Function
1	SDA	DIO	I ² C data input/output.
2	SCL	DI	I ² C clock input.
3	SDI	DI	I ² S data input.
4	LRCK	DI	I ² S L/R clock input.
5	SCLK	DI	I ² S bit clock input.
6	DVSS	P	Ground for digital circuits.
7	VR_DIG	P	1.8V digital supply voltage generated by internal LDO. Noted: when DVDD is 1.8V, please connect DVDD to the VR_DIG.
8	DVDD	P	3.3V, 1.8V power supply for I/O.
9, 13, 14, 15, 26, 27, 28	NC	P	No internal connection.
10	AVSS	P	Ground for analog circuits.
11	AVCC	P	26.4V power supply for analog circuits.
12	GVDD	P	Internal power supply generated by LDO.
16	BSTPR	P	Bootstrap supply for VOUTPR.
17	VOUTPR	AO	Positive output of RCH.
18	PVDDR	P	26.4V power supply for RCH.
19	VOUTNR	AO	Negative output of RCH.
20	BSTNR	P	Bootstrap supply of VOUTNR.
21	BSTNL	P	Bootstrap supply for VOUTNL.
22	VOUTNL	AO	Negative output of LCH.
23	PVDDL	P	26.4V power supply for LCH.
24	VOUTPL	AO	Positive output of LCH.
25	BSTPL	P	Bootstrap supply for VOUTPL.
29	FAULTB	DO	Fault indicator (low active).
30	A_SEL	DI	Slave address selection
31	SDO	DO	I ² S data output.
32	PWDNN	DI	Power down pin, low active.
33 (Exposed Pad)	PVSS	P	Ground. The exposed pad must be soldered to a large PCB and connected to GND for maximum power dissipation.

Functional Block Diagram

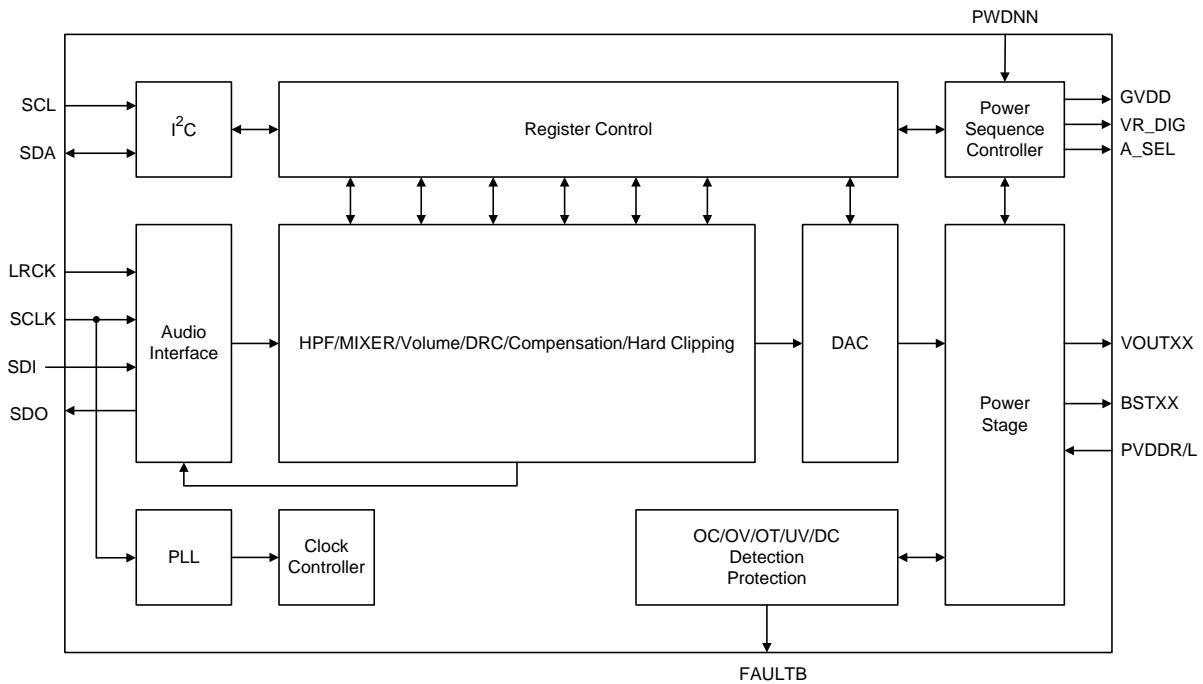

Operation

Error Reporting

The FAULTB pin is error report output pin. Any fault will pull FAULTB to low. This pin is open-drain configuration, need pull-up resistor.

Clock Detection

The RT9120M can accept SCLK to be as 32fs, 48fs and 64fs and support only a 1xf LRCK. The internal oscillator will check SCLK input constantly. If clock is lost, the RT9120M will mute and shutdown the power stage automatically.

Volume Control

The RT9120M have master volume MS_VOL and each channel volume CH1_VOL, CH2_VOL control. The step of each volume is 0.0625dB per step, from 24dB to mute. CH1 and CH2 also have each mute control, CH1_MUTE and CH2_MUTE.

Built-In Anti-POP Function

An internal soft-start function controls the Duty ramp-up rate of the output PWM voltage to minimize the POP noise during start-up. Similarly, when power shut-down, the duty also ramp-down to eliminate the POP noise. This function also acts when the PWDNN

pin turns-ON/OFF.

Overcurrent Protection

The RT9120M provides OCP function to prevent the device from damages during overload or short-circuit conditions. The current is detected by an internal sensing circuit. Once overload or short-circuit happens, the OCP function is designed to turn off the output immediately.

Undervoltage Protection

The RT9120M monitors the voltage on PVDD voltage threshold. When the voltage on PVDDL/R pin falls below the undervoltage threshold, 4V (typ.) which can be programmable, the UVP circuit turns off the output immediately. Or the latch mode can be configured to use.

Overvoltage Protection

The RT9120M monitors the voltage on PVDD voltage threshold. When the voltage on PVDDL/R pin rise behind the overvoltage threshold, 30V, the OVP circuit turns off the output immediately and operates in cycle by cycle auto-recovery mode. Or the latch mode can be configured to use.

Over-Temperature Protection

The over-temperature protection function will turn off the power MOSFET when the junction temperature exceeds 150°C (minimum). Once the junction temperature cools down by approximately 30°C, the regulator will automatically resume operation. Or the latch mode can be configured to use.

Dynamic Range Enhancement

The dynamic range enhancement which enhance the dynamic range for the application. It will optimize the noise when the operating.

Absolute Maximum Ratings (Note 1)

- Supply Voltage, AVCC, PVDDL, PVDDR ----- -0.3V to 32V
- Supply Voltage, DVDD ----- -0.3V to 9V
- Speaker Amplifier Output Voltage, VOUTXX ----- -0.3V to 32V
- BSTXX (Note 2) ----- -0.3V to 36V
- SCL, SDA, FAULTB ----- -0.3V to 6V
- LRCK, SCLK, SDI, PWDNN, A_SEL ----- -0.3V to DVDD + 0.5V
- GND to PVSS, DVSS and AVSS ----- -0.3V to 0.3V
- VOUTPR, VOUTNR, VOUTPL, VOUTNL (Note 3) ----- -10V to 37V
- SDO ----- -0.3V to 9V
- VR_DIG ----- -0.3V to 4V
- GVDD ----- -0.3V to 6V
- Power Dissipation, Pd @ TA = 25°C
 VQFN-32L 5x5 ----- 3.63W
- Package Thermal Resistance (Note 4)
 VQFN-32L 5x5, θ_{JA} ----- 27.5°C/W
 VQFN-32L 5x5, θ_{JC} ----- 7°C/W
 Lead Temperature (Soldering, 10sec.) ----- 260°C
 Junction Temperature ----- 150°C
- Storage Temperature Range ----- -65°C to 150°C
- ESD Susceptibility (Note 5)
 HBM (Human Body Model) ----- 2kV

Recommended Operating Conditions (Note 6)

- Supply Input Voltage, DVDD ----- 3V to 3.6V
- Supply Input Voltage (For 1.8V I/O), DVDD, VR_DIG ----- 1.62V to 1.98V
- Supply Input Voltage, PVDDL, PVDDR, AVCC ----- 4.5V to 26.4V
- Ambient Temperature Range ----- -40°C to 85°C
- Junction Temperature Range ----- -40°C to 150°C

Electrical Characteristics

(PVDDL = PVDDR = AVCC = 12V, DVDD = 3.3V, RL = 8Ω, TA = 25°C, fSW = 384kHz, L=10μH, C = 0.47μF, unless otherwise specified.) (Note 7)

Parameter		Symbol	Test Conditions	Min	Typ	Max	Unit
PWDNN, A_SEL	VIH: High-Level-Input Voltage	VIH		DVDD x 0.7	--	--	V
	VIL: Low-Level-Input Voltage	VIL		--	--	DVDD x 0.3	
FAULTB	VOL: Low-Level-Output Voltage	VOL	IPULLUP = 3mA	--	--	0.4	V

Parameter	Symbol	Test Conditions	Min	Typ	Max	Unit	
DVDD Quiescent Current (Normal Mode)	I _{Q_D}	PWDNN = 3.3V/1.8V, 0dBFS input, for DVDD, no load, no LC filter	--	7.5	15	mA	
DVDD Shut Down Current	I _{SD_D}	PWDNN = 0.8V/0.5V, for DVDD, no load, no LC filter	--	--	15	μA	
PVDDL/R + AVCC Quiescent Current (Normal Mode)	I _{Q_P}	PWDNN = 3.3V, switch 50% duty for PVDD = 12, no load, no LC filter	--	20	25	mA	
PVDDL/R + AVCC Shut Down Current	I _{SD_P}	PWDNN = 0.8V, no load for PVDD, no load, no LC filter	--	--	20	μA	
Drain-Source On-State Resistance	R _{DS(ON)}	PVDD = 12V, I _{OUT} = 500mA, T _J = 25°C	High-side	--	190	--	mΩ
			Low-side	--	170	--	
Speaker Gain Variation	ΔA _{V(SPK_AMP)}		-0.5	--	0.5	dB	
Startup Time from Shut Down	t _{ON}		--	80	--	ms	
Shut Down Time from Enable	t _{OFF}		--	60	--	ms	
PWM Switching Frequency	f _{sw}	400kHz mode	300	400	500	kHz	
		800kHz mode	600	800	1000		
RMS Output Power BD Modulation	P _O	THD + N = 10% (BTL)	8	9	--	W	
		THD + N = 1% (BTL)	--	6.5	--		
		PVCC = 20V, THD + N = 1% (BTL)	--	20	--		
Total Harmonic Distortion + Noise	THD+N	P _O = 1W (BTL)	--	0.03	0.1	%	
Output Integrated Noise	V _n	20Hz to 20kHz, A-weighted, PVDD = 24V	--	45	--	μV	
Output Offset Voltage	V _{OS}		-6.5	--	6.5	mV	
Cross-Talk	X _{TALK}	Output power = 1W, none shielding choke	--	-75	--	dB	
		Output power = 1W, with shielding choke	--	-100	--		
Signal-to-Noise Ratio	SNR	A-Weighting	--	108	--	dB	
Power Supply Rejection Ratio	PSRR	Frequency @ 1kHz	--	-75	--	dB	
Efficiency	η	Output power = 10W + 10W	--	92	--	%	
Over-Temperature Protection	OTP	Guaranteed by design	150	160	175	°C	
Thermal Hysteresis			--	30	--	°C	
Overcurrent Protection	OCP	BTL	4	5	6	A	
		PBTL	8	10	12		
PVDDL/PVDDR Overvoltage	OVP		--	30	--	V	
PVDDL/PVDDR Undervoltage	UVP	Programmable	--	4	--	V	
I²C Interface Electrical Characteristics							
High-Level Input Voltage (Belongs to the internal 1.8V domain)	V _{IH}		VR _{DIG} x 0.7	--	--	V	

Parameter		Symbol	Test Conditions	Min	Typ	Max	Unit
Low-Level Input Voltage (Belong to the internal 1.8V domain)		V _{IL}		--	--	V _{R_{DIG}} x 0.3	V
Digital Output Low (SDA)		V _{OL}	IPULLUP = 3mA	--	--	0.4	V
Clock Operating Frequency		f _{SCL}		--	--	400	kHz
Bus Free Time Between Stop and Start Condition		t _{BUF}		1.3	--	--	μs
Hold Time After (Repeated) Start Condition		t _{HD,STA}		0.6	--	--	μs
Repeated Start Condition Setup Time		t _{SU,STA}		0.6	--	--	μs
Stop Condition Time		t _{SU,STD}		0.6	--	--	μs
Input Data Hold Time		t _{HD,DAT(IN)}		0	--	900	ns
Data Setup Time		t _{SU,DAT}		100	--	--	ns
Clock Low Period		t _{LOW}		1.3	--	--	μs
Clock High Period		t _{HIGH}		0.6	--	--	μs
Clock Data Fall Time		t _F		20	--	300	ns
Clock Data Rise Time		t _R		20	--	300	ns
Spike Suppression Time		t _S		--	--	20	ns
Slave Mode I²S Interface Electrical Characteristics (3.3V I/O)							
High-Level Input Voltage		V _{IH}		2.5	--	--	V
Low-Level Input Voltage		V _{IL}		--	--	0.8	V
SDO	VOH: High-Level Output Voltage	V _{OH}		--	3.3	--	V
	VOL: Low-Level Output Voltage	V _{OL}		--	--	0.4	
Slave Mode I²S Interface Electrical Characteristics (1.8V I/O)							
High-Level Input Voltage		V _{IH}		1.45	--	--	V
Low-Level Input Voltage		V _{IL}		--	--	0.5	V
SDO	VOH: High-Level Output Voltage	V _{OH}		--	1.8	--	V
	VOL: Low-Level Output Voltage	V _{OL}		--	--	0.2	
Frequency		f _{SCLKIN}		0.256	--	24.576	MHz
Setup Time, LRCK to SCLK Rising Edge		t _{su1}		10	--	--	ns
Hold Time, LRCK from SCLK Rising Edge		t _{h1}		10	--	--	ns
Setup Time, SDIN to SCLK Rising Edge		t _{su2}		10	--	--	ns
Hold Time, SDIN from SCLK Rising Edge		t _{h2}		10	--	--	ns

Parameter	Symbol	Test Conditions	Min	Typ	Max	Unit
Rise/Fall Time for SCLK/LRCK	t_r/t_f		--	--	20	ns
I ² S Duty Cycle for Rising	%		40	--	60	%

Note 1. Stresses beyond those listed under “Absolute Maximum Ratings” may cause permanent damage to the device. These are stress ratings only, and functional operation of the device at these or any other conditions beyond those indicated in the operational sections of the specifications is not implied. Exposure to absolute maximum rating conditions may affect device reliability.

Note 2. The result is defined when the cross voltage between BST and VOUT is 5V.

Note 3. The switching terminal should be used within AC peak limits. Overshoot and undershoot must be less than 100ns.

Note 4. θ_{JA} is measured under natural convection (still air) at $T_A = 25^\circ\text{C}$ with the component mounted on a high effective-thermal-conductivity four-layer test board on a JEDEC 51-7 thermal measurement standard. θ_{JC} is measured at the top of the package.

Note 5. Devices are ESD sensitive. Handling precautions are recommended.

Note 6. The device is not guaranteed to function outside its operating conditions.

Note 7. Measurements were made using the RT9120M_EVM board and Audio Precision System 2722 with AUX-0025 low-pass filter.

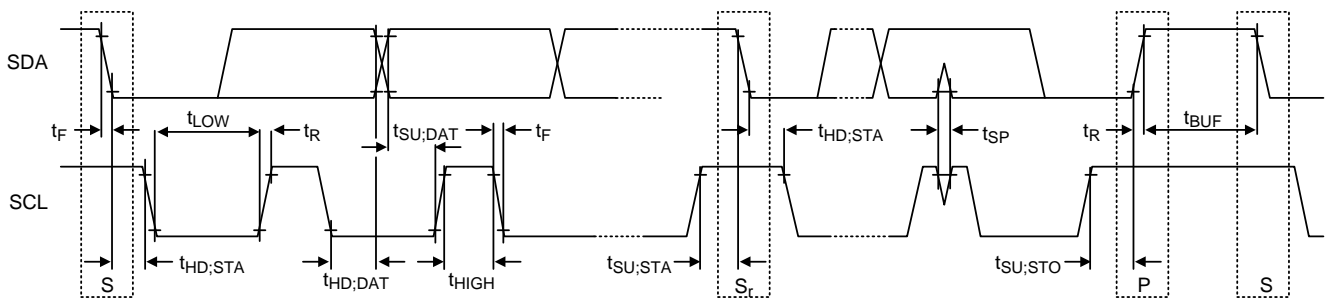

Figure 1. I²C Interface Timing Diagram

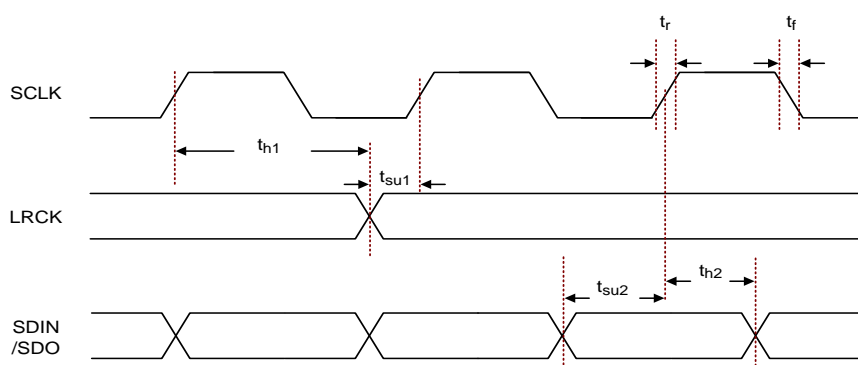
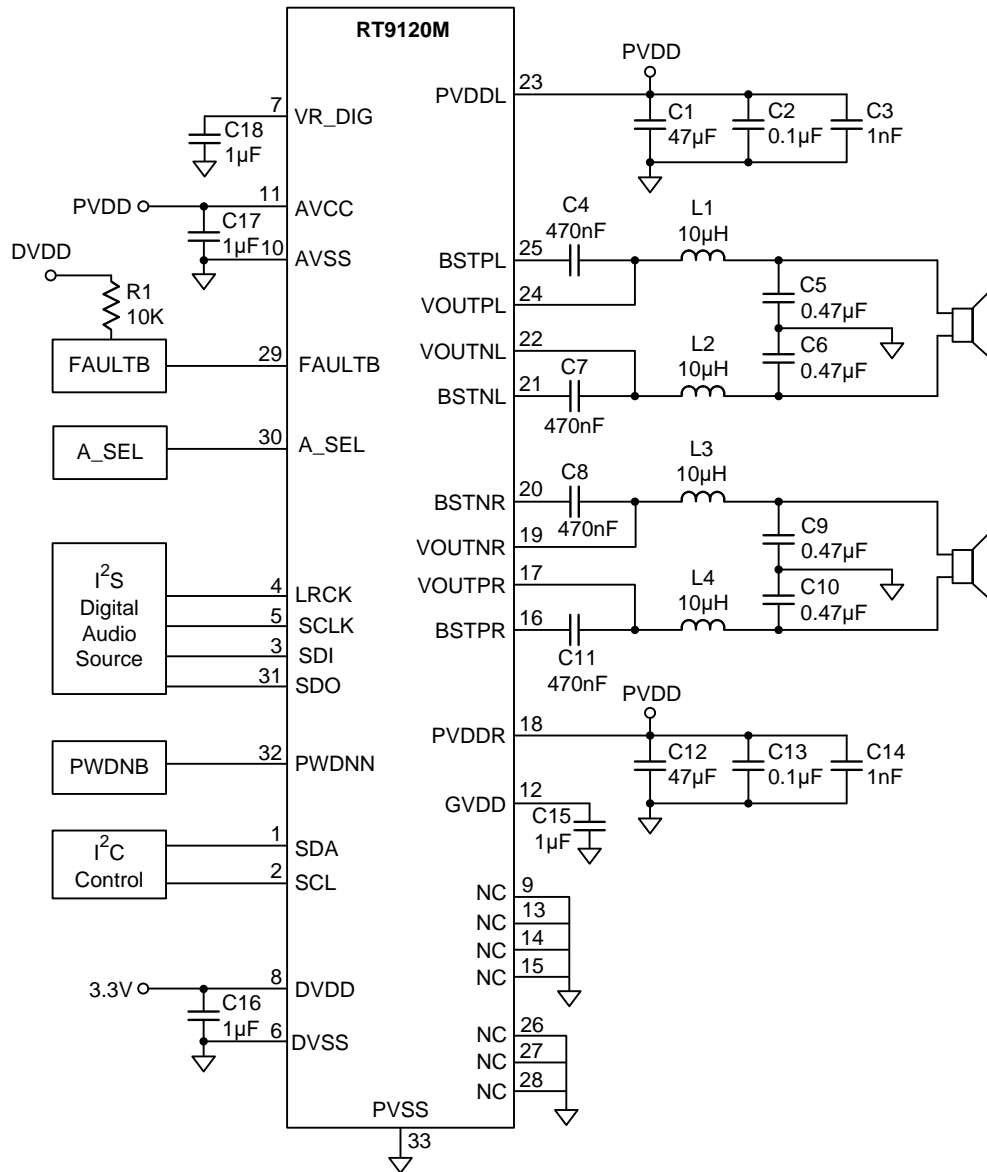

Figure 2. Timing Diagram of Slave Mode I²S Interface

Typical Application Circuit

3.3V I/O Application



1.8V I/O Application

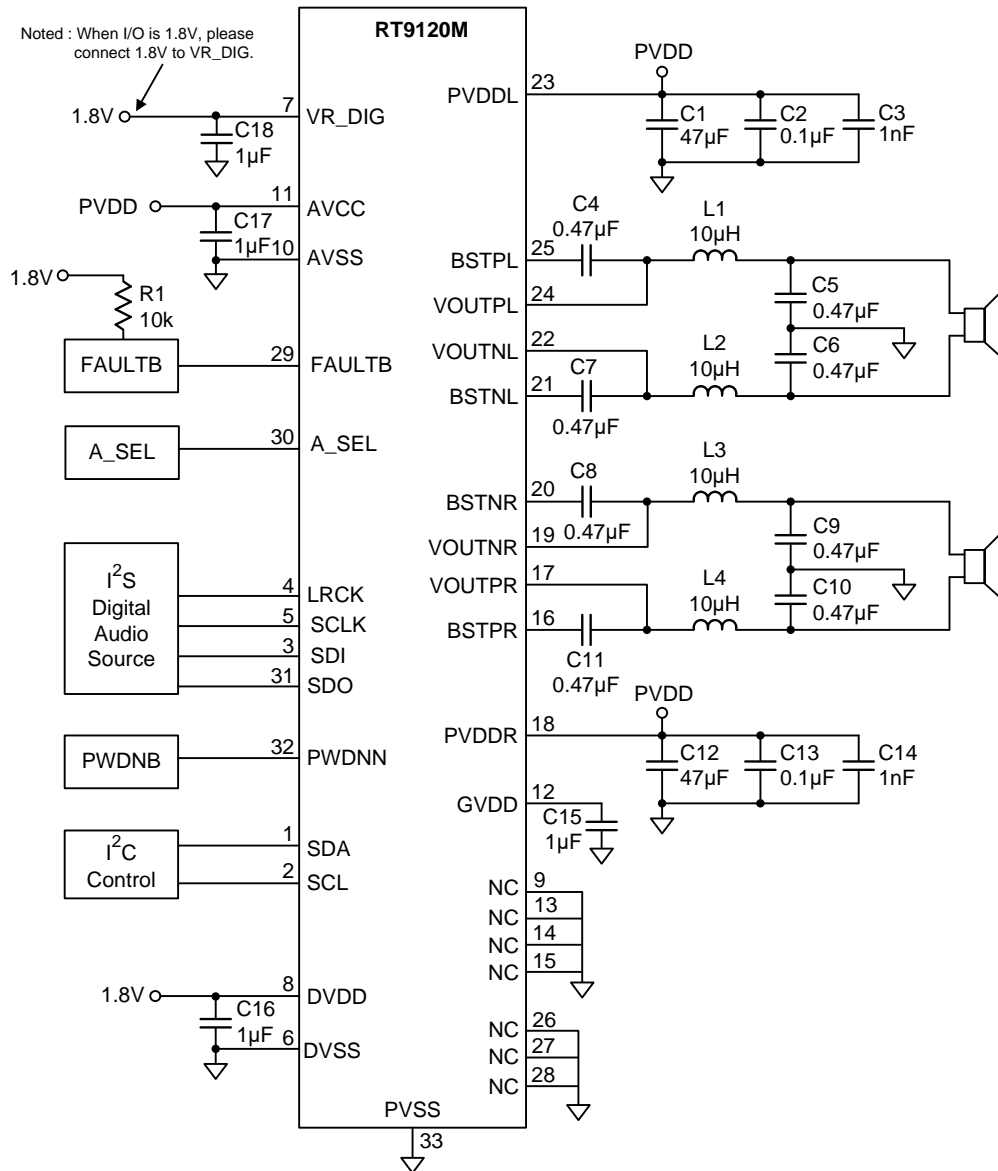

Power-On Sequence

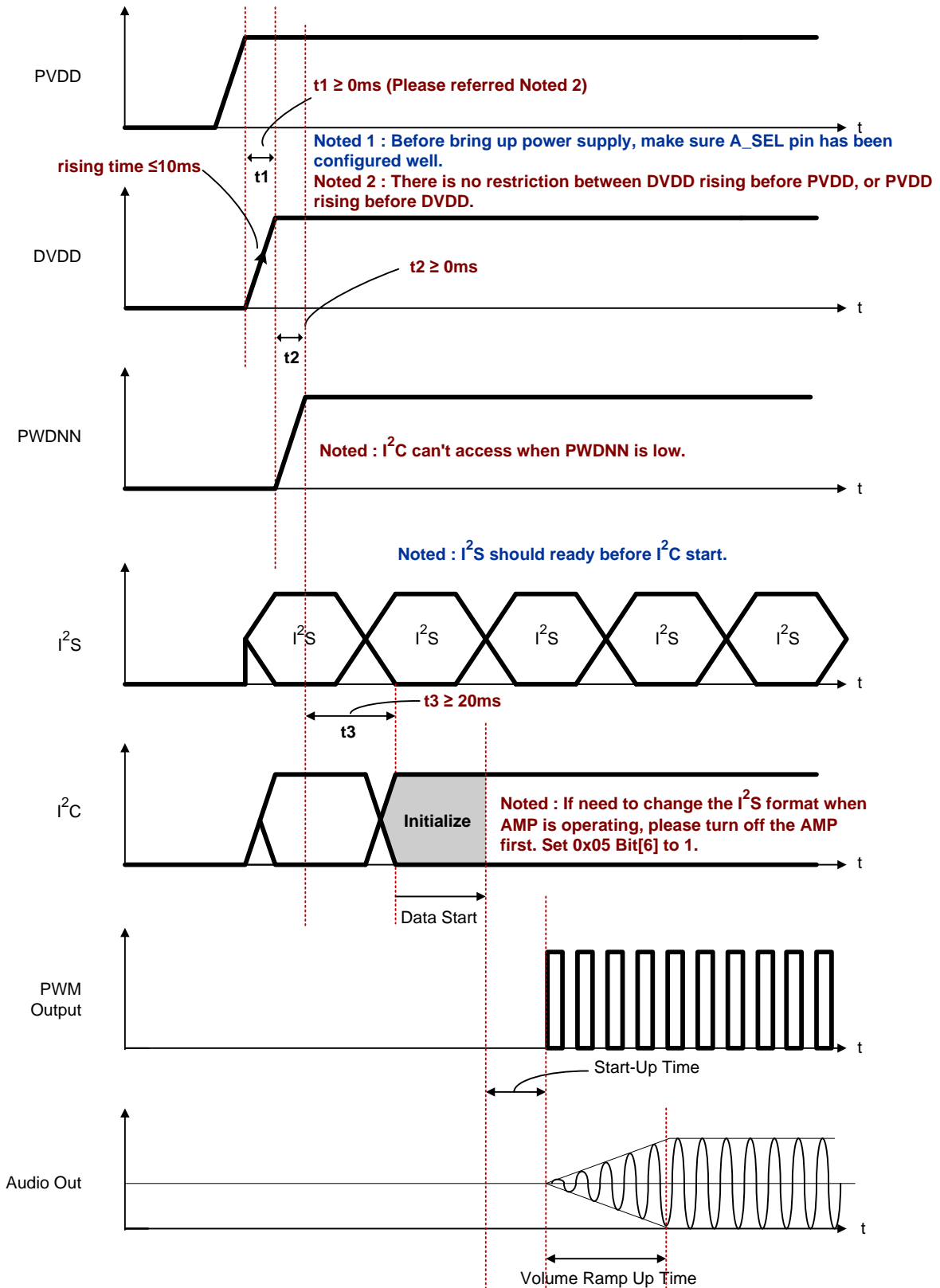

Power-Off Sequence

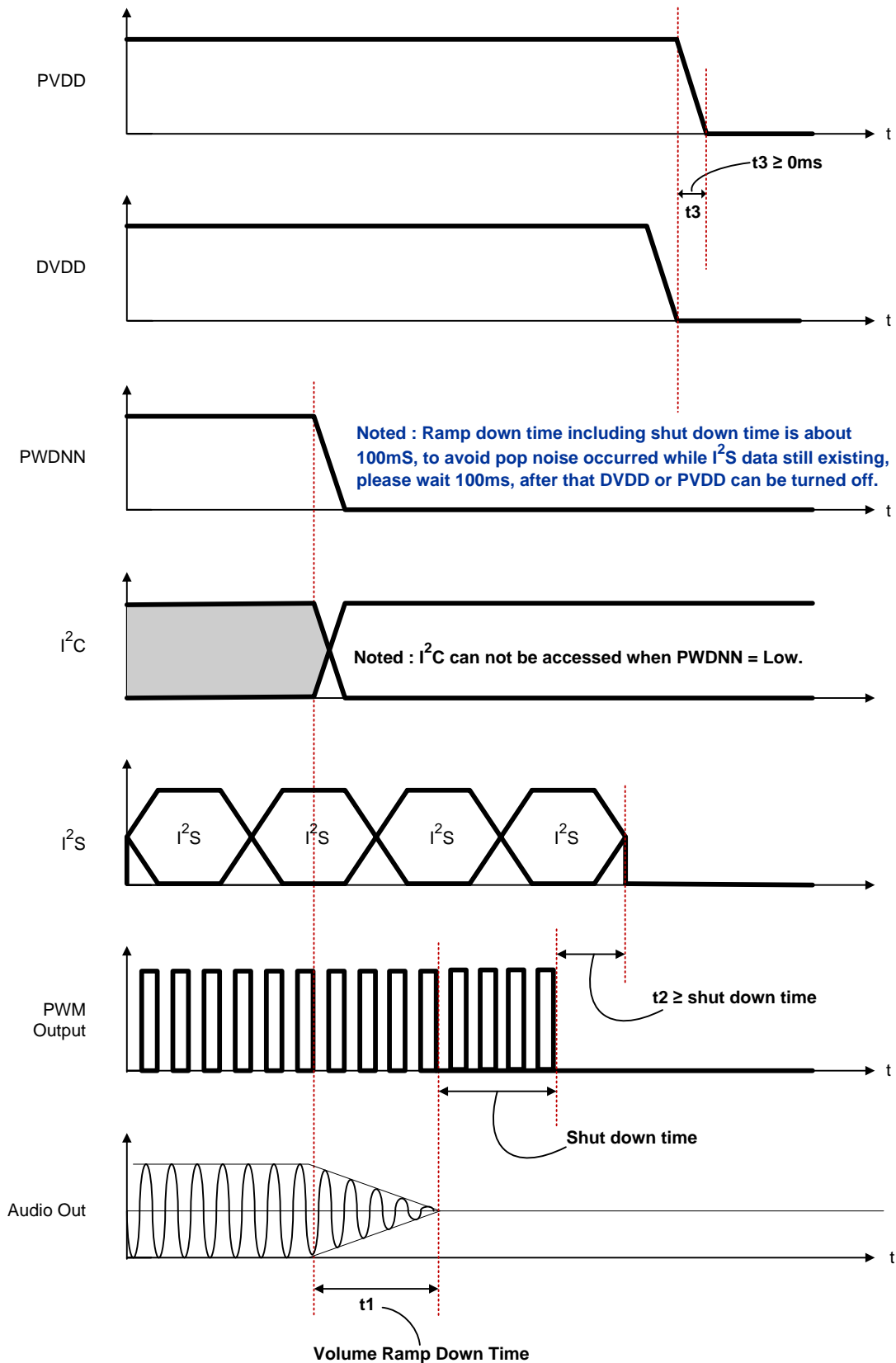

Initial Sequence (BTL Mode)

Sequence	reg_addr	reg_size	reg_value	Description	
1	0x40	1	0x80	SW reset, if HW reset has been done (PWDNN set to low), there is no need to do the SW reset.	Initial setting
>20ms delay					
2	0x07	1	0x07	Analog gain (Optional)	
3	0x65	1	0x04	Internal setting	
4	0x6C	1	0xC0	DVDD = 1.8V, Set 0x6C to 0xC0. DVDD = 3.3V, no need to adjust.	
5	0x20	2	0x01, 0x80	Set the volume from mute to 0dB	
6	0x05	1	0x80	Amp turn on (PWM = 384kHz)	Amp turn on
7	0x05	1	0x84	Amp turn on (PWM = 800kHz)	Amp turn on

Initial Sequence (PBTL Mode)

Sequence	reg_addr	reg_size	reg_value	Description	
1	0x40	1	0x80	SW reset, if HW reset has been done (PWDNN set to low), there is no need to do the SW reset.	Initial setting
>20ms delay					
2	0x20	2	0x01, 0x80	Set the volume from mute to 0dB	
3	0x65	1	0x04	Internal setting	
4	0x6C	1	0xC0	DVDD = 1.8V, Set 0x6C to 0xC0. DVDD = 3.3V, no need to adjust.	
5	0x07	1	0x07	Analog gain (Optional)	
6	0x30	3	0x01, 0xC0, 0x07	Set input mixing = L/2+R/2 for mono mode	
7	0x31	3	0x01, 0xC0, 0x07		
8	0x05	1	0x88	Set to PBTL and Amp turn on (PWM is 384kHz)	Amp turn on
9	0x05	1	0x8C	Amp turn on (PWM = 800kHz)	Amp turn on

Typical Characteristics

PWM = 400kHz

Power Supply Voltage vs. Current Consumption

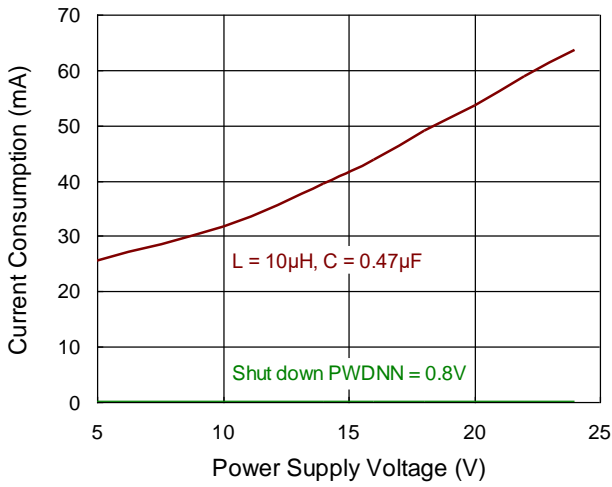

Output Power vs. Efficiency (BTL)

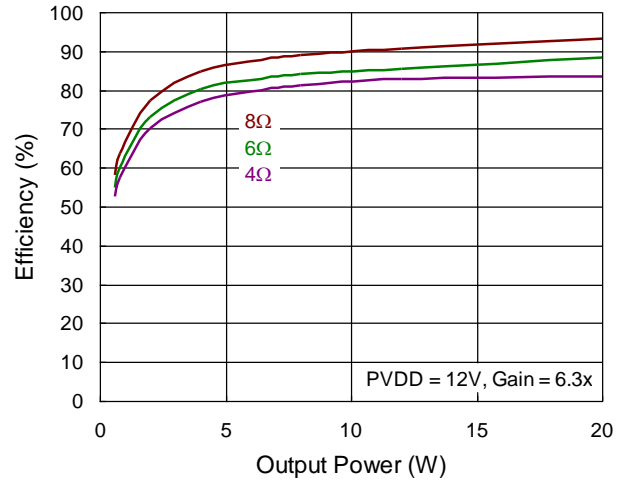

Output Power vs. Efficiency (BTL)

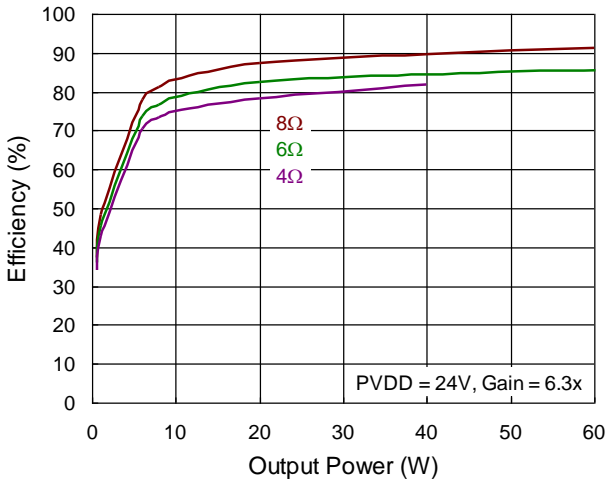

Output Power vs. Efficiency (PBTL)

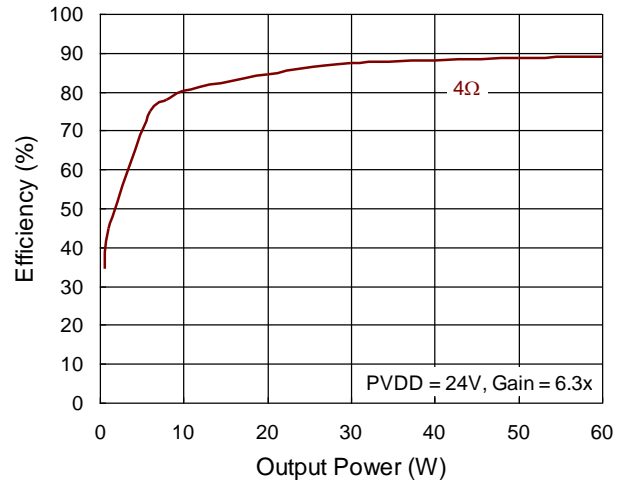

THD+N vs. Output Power (BTL)

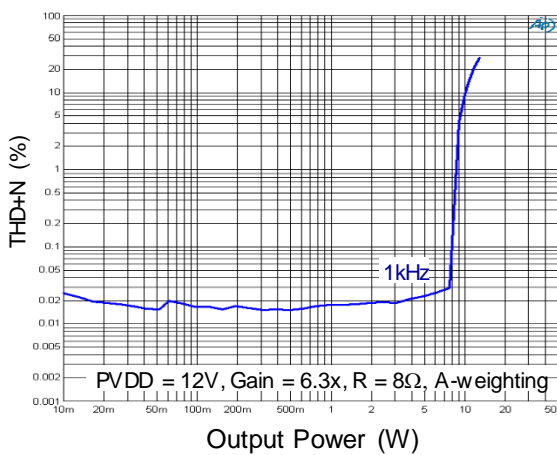

THD+N vs. Output Power (BTL)

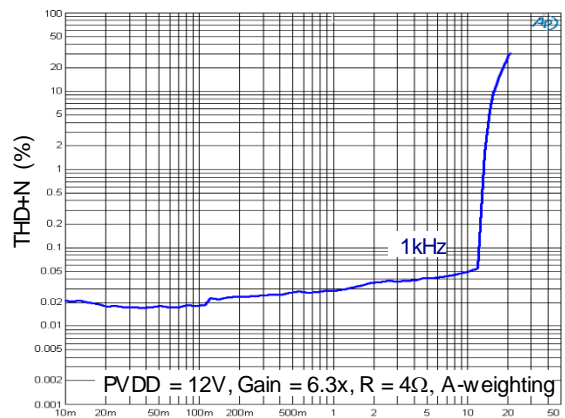

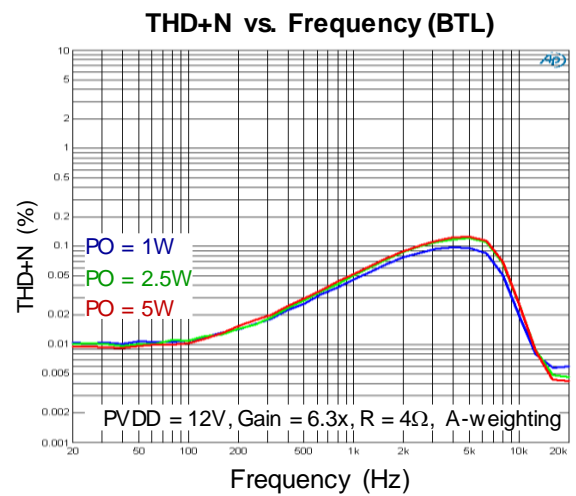
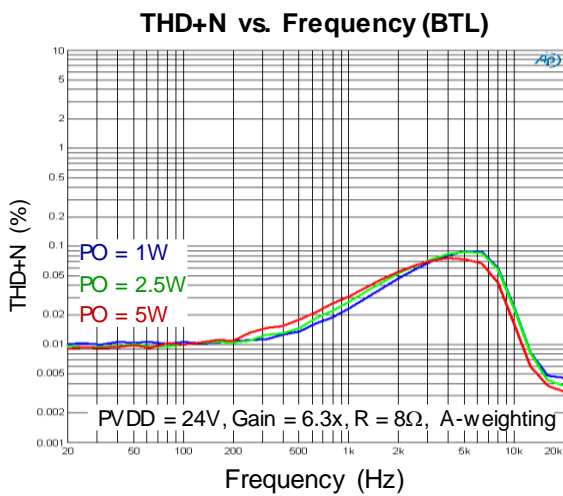
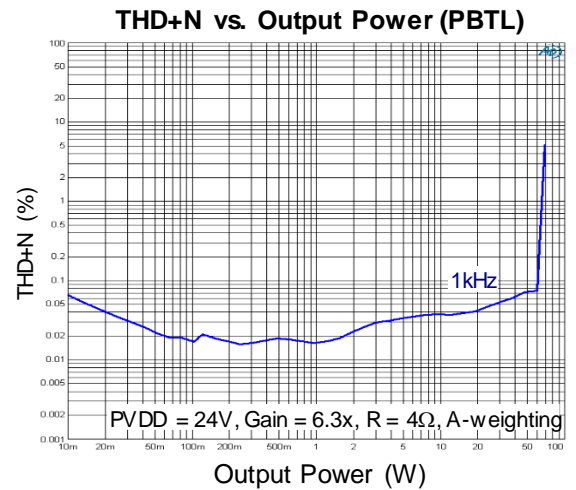
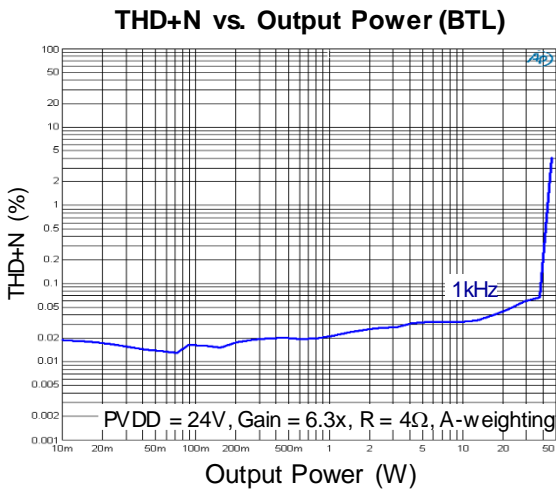
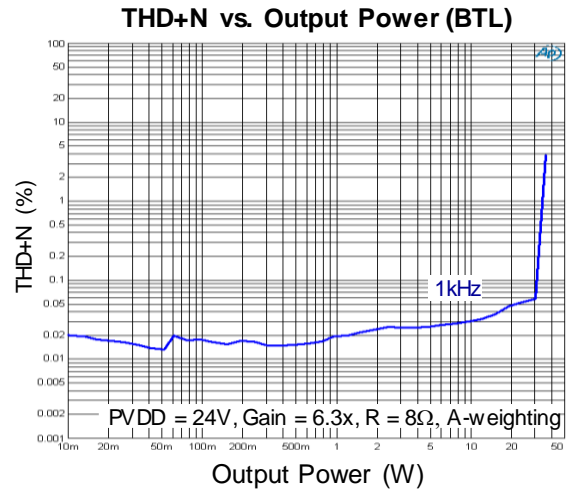
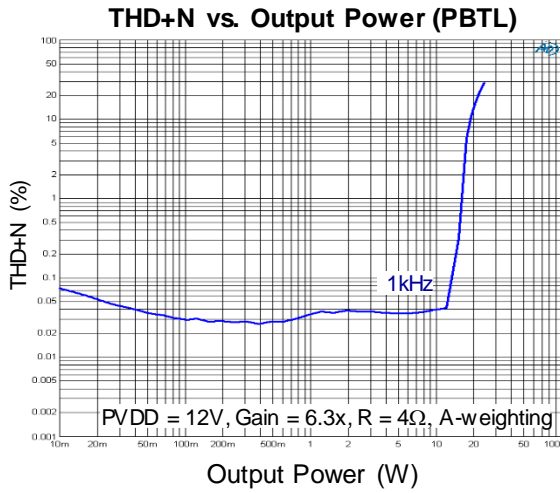

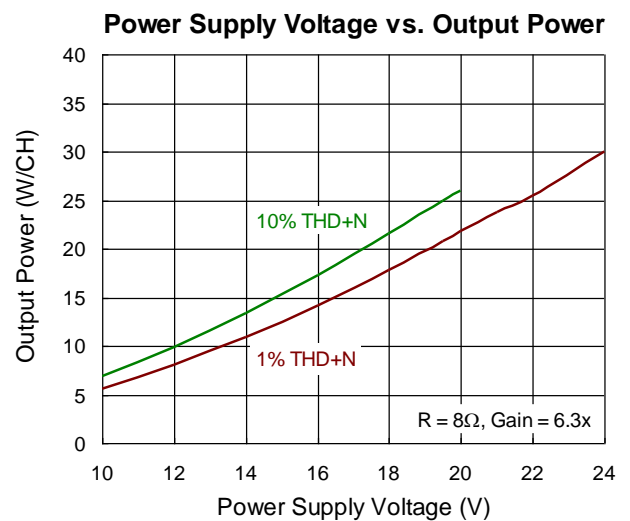
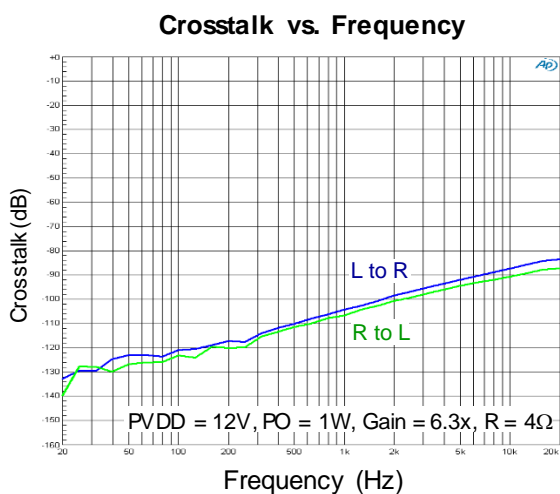
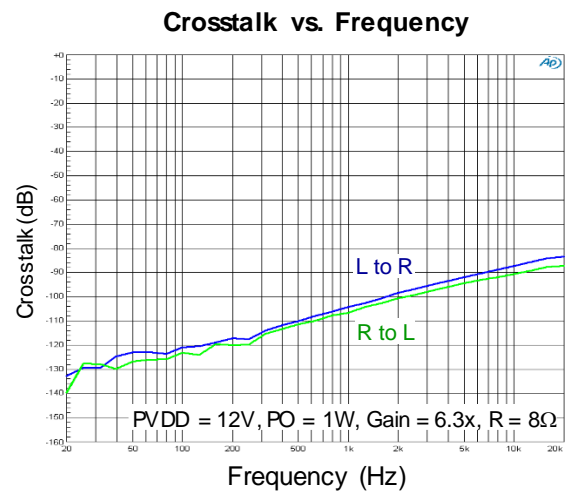
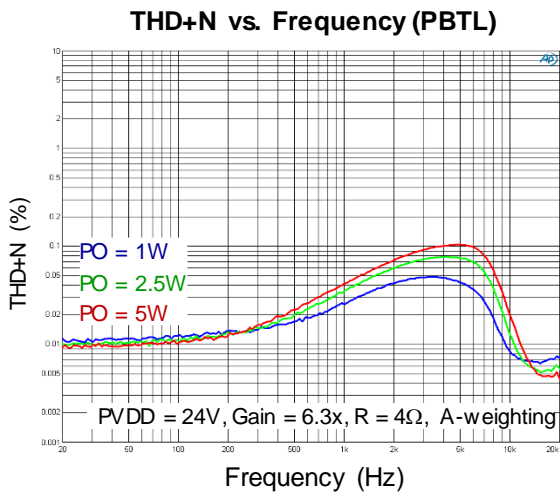
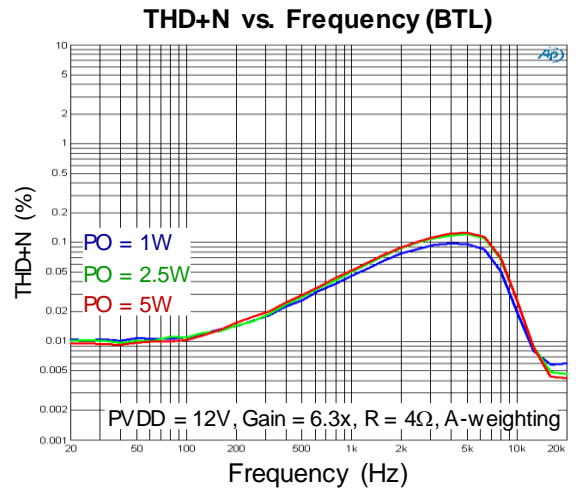
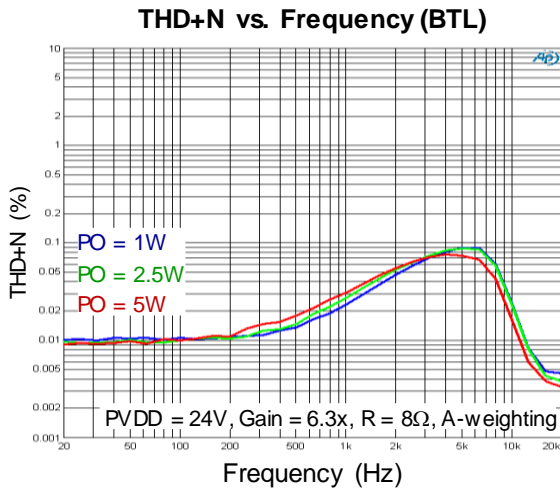

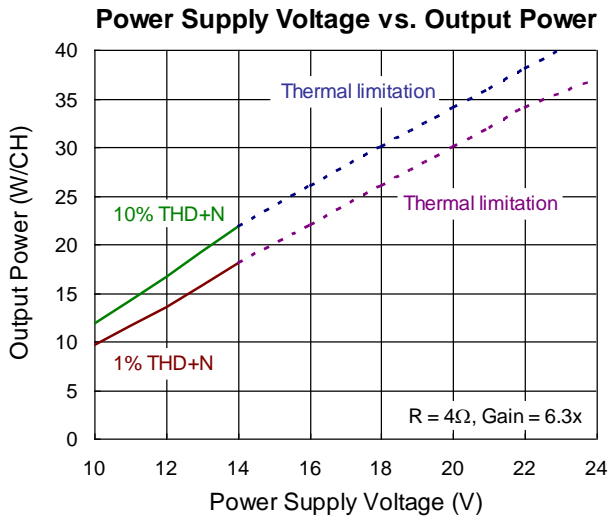

Noted: Measurements were made using the RT9120M_EVM board and Audio Precision System 2722 with AUX0025 low-pass filter. All measurements taken with 1kHz.

Signal Path

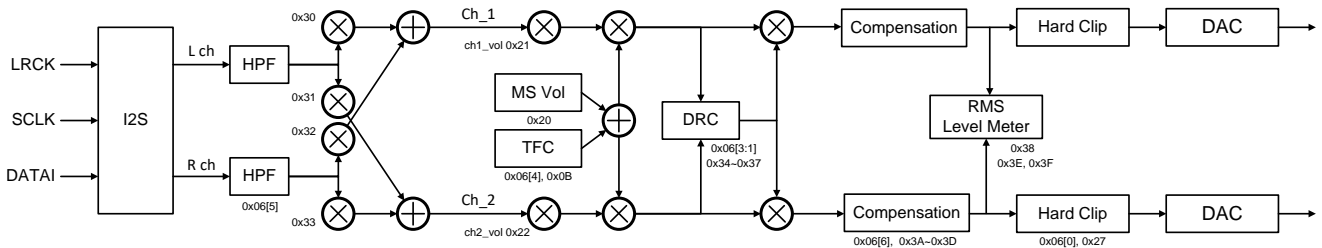

Input High Pass Filter

Block Diagram & Description

→ There are DC-Cut filter for each output filter. The cut off frequency is 1.5Hz.

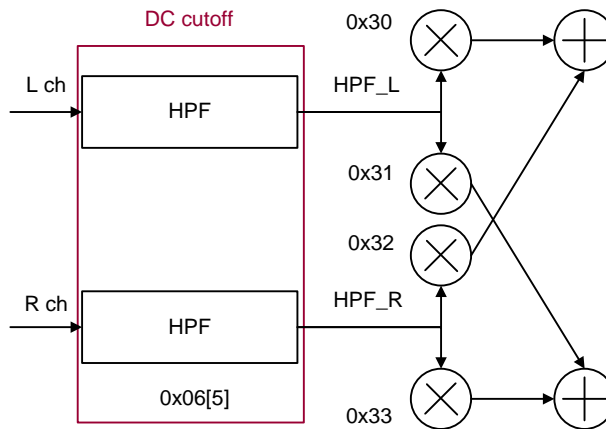

Address	BITS	Name	Description
0x06	5	HPF_EN	0: Input high pass filter disable 1: Input high pass filter enable

DRC

DRC Description	Address	Description
DRC_T: Threshold	0x23	<p>The graph illustrates the DRC function. The vertical axis is 'Output Level' and the horizontal axis is 'Input Level'. A solid line represents the linear relationship. At the 'DRC_T' threshold, the signal is compressed. The 'DRC_O' parameter is shown as a vertical offset. The 'DRC_RATIO' parameter is shown as the slope of the compressed signal. A horizontal dotted line is labeled 'Compressor/Limit'.</p>
DRC_RATIO: Compress ratio	0x24	
DRC_O: Make up gain	0x25	
DRC_N_T: Noise gate threshold	0x26	
Noise gate enable	0x06	

DRC Enable

Address	BITS	Name	Description
0x06	2	DRC_EN	0: DRC disable 1: DRC enable

DRC Noise Gate Enable

Address	BITS	Name	Description
0x06	1	DRC_N_EN	0: DRC Noise gate disable 1: DRC Noise gate enable

DRC Control

Address	BITS	Name	Description
0x23	10:0	DRC_TH[10:0]	TH[10:0], DRC Threshold
0x24	7:0	DRC_RATIO[7:0]	RATIO[7:0] DRC compression ratio
0x25	10:0	DRC_O[10:0]	O[10:0] DRC make up gain
0x26	10:0	DRC_N_T[10:0]	N_T[10:0] DRC Noise gate of the DRC

DRC Timing

Address	BITS	Name	Description
0x34	16:0	DRC_AE[16:0]	DRC_AE[16:0], DRC Energy estimator
0x35	16:0	DRC_1_AE[16:0]	DRC_1_AE[16:0], DRC Energy estimator (release)
0x36	16:0	DRC_AD[16:0]	DRC_AD[16:0] DRC release time
0x37	16:0	DRC_AA[16:0]	DRC_AA[16:0] DRC attack time

DRC Timing Equation

DRC Description	Equation																								
AA/AE/AD/1-AE Timing Equation	Equation: $AA = (1 - e^{-2.2/(ta*fs)}) \times 2^{15}$ ta = AA/AD/AE timing, fs = sampling rate Ex: ta = 0.15ms, fs = 48k $AA = (1 - e^{-2.2/(0.00015*48000)}) \times 2^{15} = 8627.352$ DEC = 8627 HEX = 0x21B3																								
	<table border="1"> <thead> <tr> <th>Threshold</th> <th>T_Dec</th> <th>T_Hex</th> </tr> </thead> <tbody> <tr> <td>0.15ms</td> <td>8627</td> <td>0x21B3</td> </tr> <tr> <td>.</td> <td>.</td> <td>.</td> </tr> <tr> <td>.</td> <td>.</td> <td>.</td> </tr> <tr> <td>400ms</td> <td>3.75</td> <td>0x3</td> </tr> <tr> <td>.</td> <td>.</td> <td>.</td> </tr> <tr> <td>.</td> <td>.</td> <td>.</td> </tr> <tr> <td>.</td> <td>.</td> <td>.</td> </tr> </tbody> </table>	Threshold	T_Dec	T_Hex	0.15ms	8627	0x21B3	400ms	3.75	0x3
	Threshold	T_Dec	T_Hex																						
	0.15ms	8627	0x21B3																						
	.	.	.																						
.	.	.																							
400ms	3.75	0x3																							
.	.	.																							
.	.	.																							
.	.	.																							
Noted: For the different Sampling Rate, the maximum timing will be																									
	<table border="1"> <thead> <tr> <th>fs (Sampling Rate)</th> <th>Max Time (Unit: S)</th> </tr> </thead> <tbody> <tr> <td>192kHz</td> <td>0.375</td> </tr> <tr> <td>96kHz</td> <td>0.750</td> </tr> <tr> <td>48khz</td> <td>1.500</td> </tr> <tr> <td>32kHz</td> <td>2.250</td> </tr> <tr> <td>24kHz</td> <td>3.000</td> </tr> <tr> <td>16kHz</td> <td>4.500</td> </tr> <tr> <td>12kHz</td> <td>6.000</td> </tr> <tr> <td>8kHz</td> <td>9.000</td> </tr> </tbody> </table>	fs (Sampling Rate)	Max Time (Unit: S)	192kHz	0.375	96kHz	0.750	48khz	1.500	32kHz	2.250	24kHz	3.000	16kHz	4.500	12kHz	6.000	8kHz	9.000						
fs (Sampling Rate)	Max Time (Unit: S)																								
192kHz	0.375																								
96kHz	0.750																								
48khz	1.500																								
32kHz	2.250																								
24kHz	3.000																								
16kHz	4.500																								
12kHz	6.000																								
8kHz	9.000																								

DRC Description	Equation																					
DRC_T: Threshold	<p>T is the threshold of the DRC Equation: $T = -(\text{Threshold})/0.0625$ (dB) Ex: $T = -10\text{dB}$, $-(-10)/0.0625 = 160$ $T_Dec = 160$ $T_Hex = \text{DEC2HEX}(160) = 0xA0$</p> <table border="1" data-bbox="536 470 1104 739"> <thead> <tr> <th>Threshold</th> <th>T_Dec</th> <th>T_Hex</th> </tr> </thead> <tbody> <tr> <td>-10dB</td> <td>160</td> <td>0xA0</td> </tr> <tr> <td>.</td> <td>.</td> <td>.</td> </tr> <tr> <td>.</td> <td>.</td> <td>.</td> </tr> <tr> <td>-15dB</td> <td>240</td> <td>0xF0</td> </tr> <tr> <td>.</td> <td>.</td> <td>.</td> </tr> <tr> <td>.</td> <td>.</td> <td>.</td> </tr> </tbody> </table>	Threshold	T_Dec	T_Hex	-10dB	160	0xA0	-15dB	240	0xF0
Threshold	T_Dec	T_Hex																				
-10dB	160	0xA0																				
.	.	.																				
.	.	.																				
-15dB	240	0xF0																				
.	.	.																				
.	.	.																				
DRC_Ratio: Compression Ratio	<p>K is the compression ratio of the DRC Equation: $K_Hex = \text{DEC2HEX}(\text{Ratio_Value})$ EX: If compression Ratio is 50%</p> <ul style="list-style-type: none"> The Ratio_Value is $128^{0.5} = 64$ $K_Dec = 64$ $K_Hex = \text{DEC2HEX}(64) = 0x0040$ Noted: the maximum value for the full compression is 128 <table border="1" data-bbox="536 1061 1442 1352"> <thead> <tr> <th>Ratio</th> <th>K_Dec</th> <th>K_Hex</th> </tr> </thead> <tbody> <tr> <td>Full Comp (100%)</td> <td>128</td> <td>0x0080</td> </tr> <tr> <td>.</td> <td>.</td> <td>.</td> </tr> <tr> <td>.</td> <td>.</td> <td>.</td> </tr> <tr> <td>50%</td> <td>64</td> <td>0x0040</td> </tr> <tr> <td>.</td> <td>.</td> <td>.</td> </tr> <tr> <td>.</td> <td>.</td> <td>.</td> </tr> </tbody> </table>	Ratio	K_Dec	K_Hex	Full Comp (100%)	128	0x0080	50%	64	0x0040
Ratio	K_Dec	K_Hex																				
Full Comp (100%)	128	0x0080																				
.	.	.																				
.	.	.																				
50%	64	0x0040																				
.	.	.																				
.	.	.																				
DRC_O: Make Up Gain	<p>O is the offset of the DRC Equation: $\text{DRC_O} = (\text{Offset}-24)/0.0625$ EX: Offset = 0dB</p> <ul style="list-style-type: none"> $\text{Abs}[(0-24)/0.0625] = 384$ $O_Dec = 384$ $O_Hex = \text{DEC2HEX}(384) = 0x0180$ <table border="1" data-bbox="536 1626 1104 1917"> <thead> <tr> <th>Offset</th> <th>O_Dec</th> <th>O_Hex</th> </tr> </thead> <tbody> <tr> <td>0dB</td> <td>384</td> <td>0x0180</td> </tr> <tr> <td>.</td> <td>.</td> <td>.</td> </tr> <tr> <td>.</td> <td>.</td> <td>.</td> </tr> <tr> <td>10dB</td> <td>224</td> <td>0x00E0</td> </tr> <tr> <td>.</td> <td>.</td> <td>.</td> </tr> <tr> <td>.</td> <td>.</td> <td>.</td> </tr> </tbody> </table>	Offset	O_Dec	O_Hex	0dB	384	0x0180	10dB	224	0x00E0
Offset	O_Dec	O_Hex																				
0dB	384	0x0180																				
.	.	.																				
.	.	.																				
10dB	224	0x00E0																				
.	.	.																				
.	.	.																				

Peak Mode and RMS Mode

Block Diagram & Description

→The detecting threshold using different calculated methods.

Peak mode: AE and 1-AE is independent

RMS mode: $AE + (1-AE) = 1$

Address	BITS	Name	Description
0x06	3	DRC_PEAK	0: RMS mode 1: Peak mode Noted: The peak mode is recommended to use.

Input Mixer

Block Diagram & Description

→ Input mixer range is from mute to 6dB.

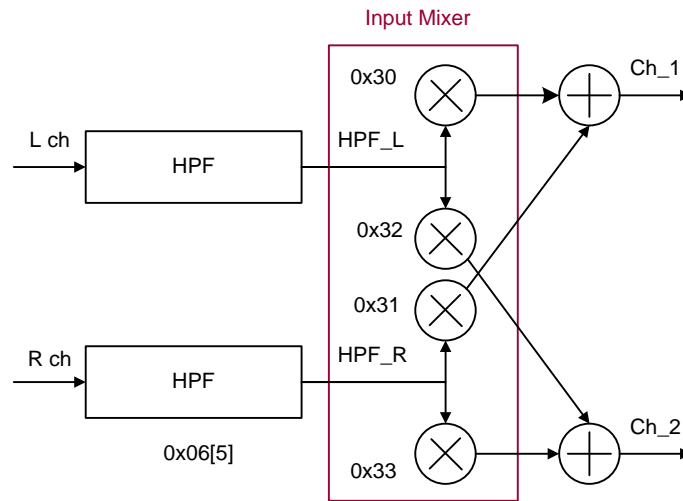

→ Default setting is CH1_IN_MIX_1 is from HPF_L

→ Default setting is CH2_IN_MIX_0 is from HPF_R

Address	BITS	Name	Description
0x30	23:0	CH1_IN_MIX_0	u[23:17], mix_0[16:0] u: Unused
0x31	23:0	CH1_IN_MIX_1	u[23:17], mix_1[16:0] u: Unused
0x32	23:0	CH2_IN_MIX_0	u[23:17], mix_0[16:0] u: Unused
0x33	23:0	CH2_IN_MIX_1	u[23:17], mix_1[16:0] u: Unused

Input Mixer Gain Setting

Address	BITS	Name	Equation																											
0x30, 0x31, 0x32, 0x33,	16:0	mix_1[16:0], mix_0[16:0]	<p>Equation: $20\text{Log}(\text{Dec}/32768)$ Range: 6dB (0xFFFF) to Mute (0x00000000) Ex: 6dB, Gain = $20\text{Log}(65535/32768) = 6\text{dB}$ Hex = 0xFFFF Dec = 65535</p> <table border="1"> <thead> <tr> <th>Gain</th> <th>Dec</th> <th>Hex</th> </tr> </thead> <tbody> <tr> <td>6dB</td> <td>65535</td> <td>0xFFFF</td> </tr> <tr> <td>2dB</td> <td>41252</td> <td>0XA124</td> </tr> <tr> <td>.</td> <td>.</td> <td>.</td> </tr> <tr> <td>.</td> <td>.</td> <td>.</td> </tr> <tr> <td>0</td> <td>32768</td> <td>0X8000</td> </tr> <tr> <td>.</td> <td>.</td> <td>.</td> </tr> <tr> <td>.</td> <td>.</td> <td>.</td> </tr> <tr> <td>.</td> <td>.</td> <td>.</td> </tr> </tbody> </table>	Gain	Dec	Hex	6dB	65535	0xFFFF	2dB	41252	0XA124	0	32768	0X8000
Gain	Dec	Hex																												
6dB	65535	0xFFFF																												
2dB	41252	0XA124																												
.	.	.																												
.	.	.																												
0	32768	0X8000																												
.	.	.																												
.	.	.																												
.	.	.																												

Mixer Inverse Phase Setting

Address	BITS	Name	Equation																											
0x30, 0x31, 0x32, 0x33,	16:0	mix_1[16:0], mix_0[16:0]	<p>Equation: Hex = DEC2HEX Ex: Gain = 6dB, Hex = 0x010000 Phase Inverse: Hex = DEC2HEX (-65535) = 0x010000</p> <table border="1"> <thead> <tr> <th>Gain</th> <th>Dec</th> <th>Hex</th> </tr> </thead> <tbody> <tr> <td>6dB</td> <td>-65535</td> <td>0X010000</td> </tr> <tr> <td>4dB</td> <td>-51791</td> <td>0x135B1</td> </tr> <tr> <td>.</td> <td>.</td> <td>.</td> </tr> <tr> <td>.</td> <td>.</td> <td>.</td> </tr> <tr> <td>0</td> <td>-32768</td> <td>0X018000</td> </tr> <tr> <td>.</td> <td>.</td> <td>.</td> </tr> <tr> <td>.</td> <td>.</td> <td>.</td> </tr> <tr> <td>.</td> <td>.</td> <td>.</td> </tr> </tbody> </table>	Gain	Dec	Hex	6dB	-65535	0X010000	4dB	-51791	0x135B1	0	-32768	0X018000
Gain	Dec	Hex																												
6dB	-65535	0X010000																												
4dB	-51791	0x135B1																												
.	.	.																												
.	.	.																												
0	-32768	0X018000																												
.	.	.																												
.	.	.																												
.	.	.																												

SDO Output Configure

Block Diagram & Description

→ The final stage of whole signal path is SDO output configure. It output the final level of each channel before digital filter. And output the I²S data before the HPF.

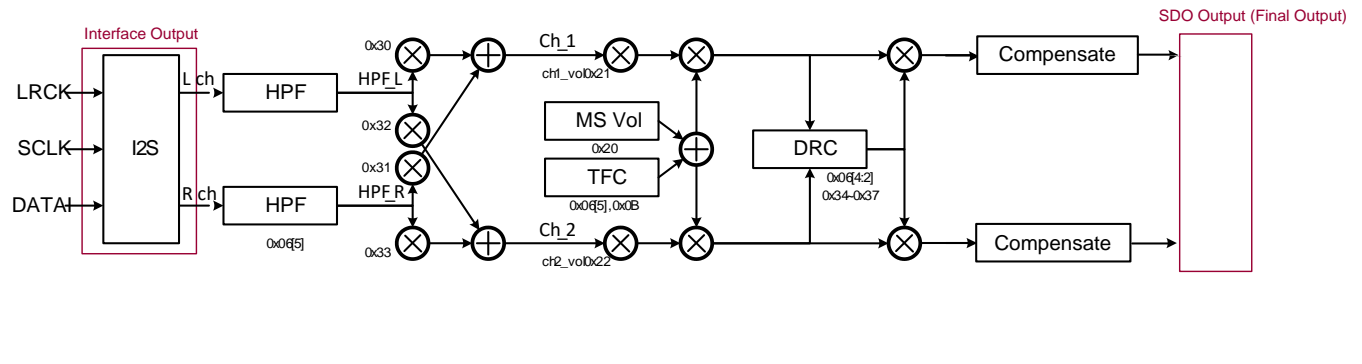

Address	BITS	Name	Description
0x04	5:4	SDO_SEL[1:0]	00: Reserved 01: Interface output 10: Final output 11: Peak level detect result

Application Information

Richtek's component specification does not include the following information in the Application Information section. Thereby no warranty is given regarding its validity and accuracy. Customers should take responsibility to verify their own designs and to ensure the functional suitability of their components and systems.

I²C Bus Specification

The RT9120M supports the I²C protocol via the input ports SCL and SDA. This protocol defines any device that sends data on to the bus as a transmitter and any device that reads the data as a receiver. The device that controls the data transfer is known as the master and the other as the slave. The master always starts the transfer and provides the serial clock for synchronization. The RT9120M is always a slave device in all of its communications. It can operate at up to 400kb/s. The RT9120M I²C interface is a slave only interface.

Communication Protocol

Data changes on the SDA line must only occur when the SCL clock is low. SDA transition while the clock is high is used to identify a START or STOP condition. START is identified by a high to low transition of the data bus SDA signal while the clock signal SCL is stable in the high state. A START condition must precede any command for data transfer. STOP is identified by low to high transition of the data bus SDA signal while the clock signal SCL is stable in the high state. A STOP condition terminates communication between the RT9120M and the bus master. During the data input, the RT9120M samples the SDA signal on the rising edge of clock SCL. For correct device operation, the SDA signal must be stable during the rising edge of the clock and the data can change only when the SCL line is low.

Boost Capacitor Selection

For the large power output, and low frequency, the boost capacitor can be choose from 0.47μF to 1μF. Reference value can referred the below table:

PVDD = 24V, R = 4Ω, Output Power > 2x20W, 20Hz, BTL Mode.	0.47μF
PVDD=24V, R=4Ω, Output Power > 60W, 20Hz, PBTL Mode	1μF
PVDD = 24V, R = 8Ω, Output Power > 35W, 20Hz, PBTL Mode	1μF

Test Condition	Capacitor Value
PVDD = 24V, R = 8Ω, Output Power > 2x25W, 20Hz, BTL Mode.	1μF

Device Addressing

The RT9120M supports I²C Control interface. The default device address is 0011011 when A_SEL = High or 0011010 when A_SEL = Low. A_SEL will latch from the power on or software reset, then define the address depends on the low, or high.

A_SEL	Device Address
High	0011011
Low	0011010

I²C Write Control

Following the START condition, the master sends a device select code with the RW bit set to 0. The RT9120M acknowledges this and the writes for the byte of internal address. After receiving the internal byte address, the RT9120M again responds with an acknowledgement.

I²C Read Control

Following the START condition the master sends a device select code with the RW bit set to 1. The RT9120M acknowledges this and then responds by sending one byte of data. The master then terminates the transfer by generating a STOP condition.

Read Function

■ Reading One Indexed Byte of Data from RT (With 1-Byte)

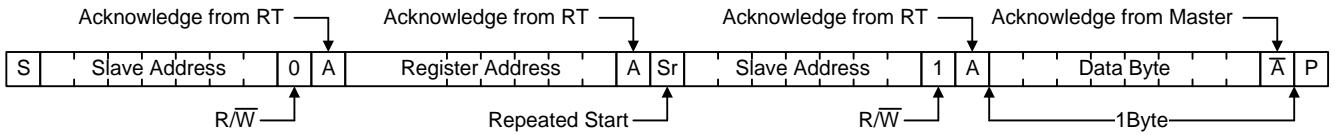

■ Reading n Indexed Words of Data from RT (With N-Byte)

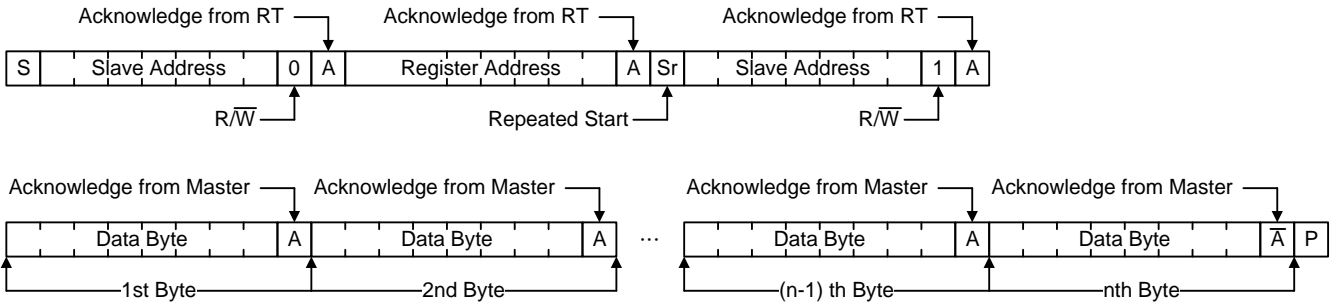

Write Function

■ Writing One Byte of Data to RT (With 1-Byte)

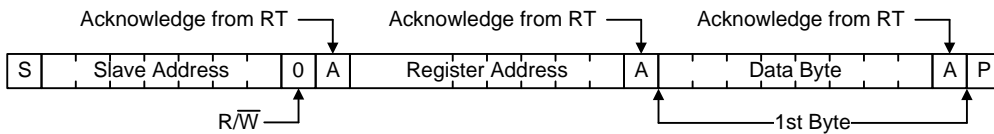

■ Writing n Bytes of Data to RT (With N-Byte)

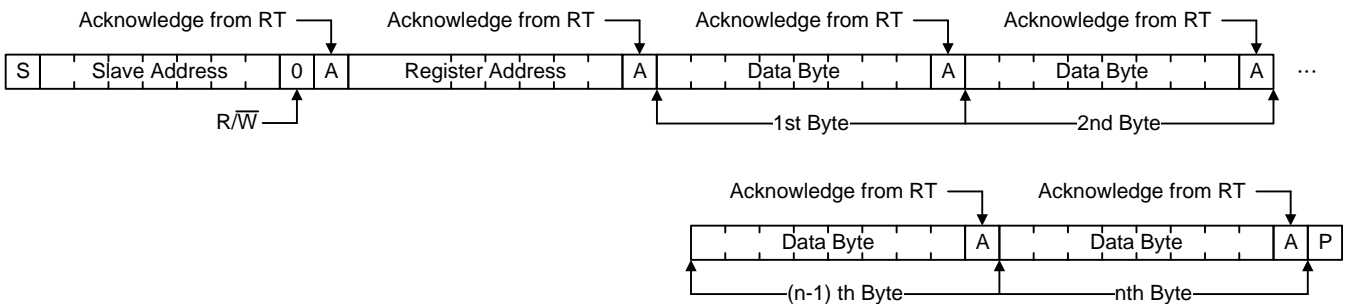

Audio Interface

The RT9120M supports three kinds of audio interface, I²S, Left justify and Right justify. Each kind of interface support 24bits, 20bits, and 16bits format. The timing diagram is shown below.

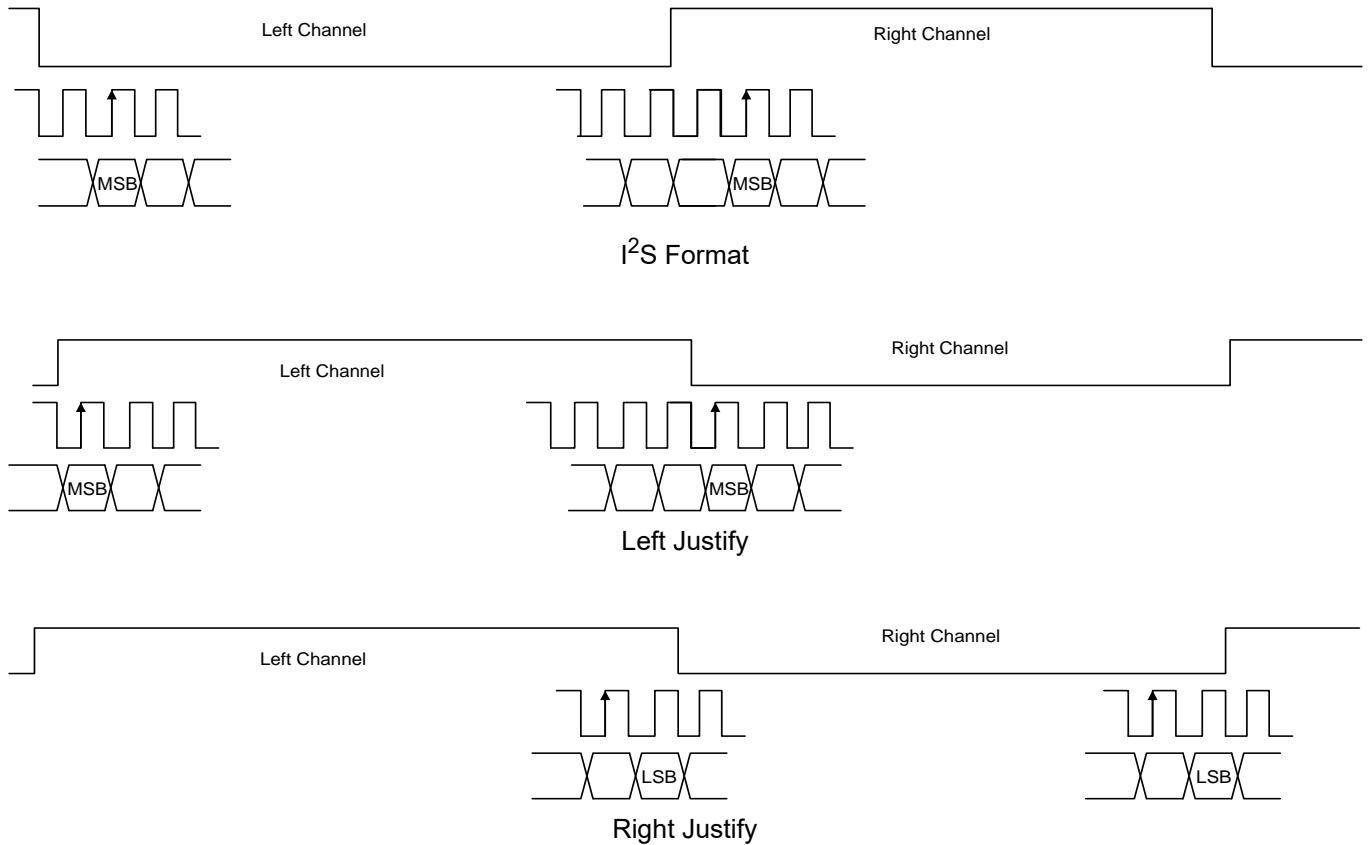

Address	BITS	Name	Description
0x02	3:2	AUD_FMT	00: I ² S (default) 01: Left Justify 10: Right Justify 11: DSP
	1:0	AUD_BITS	00: 16bits I ² S 01: 20bits I ² S 10: 24bits I ² S (default) 11: Others: Reserved

Amplification Gain

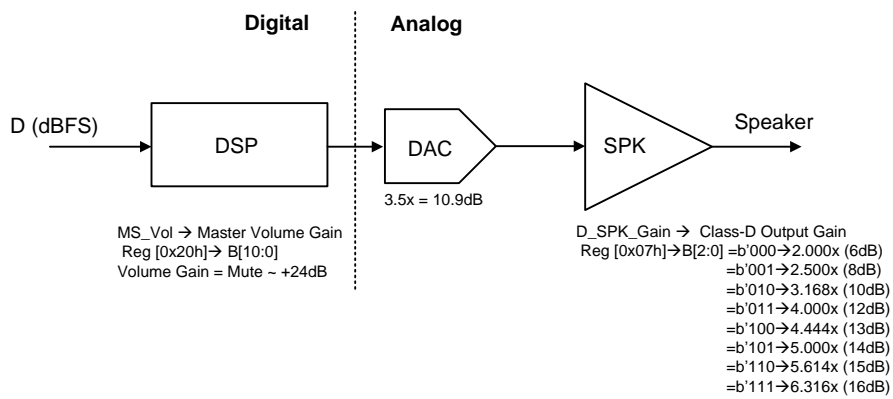

Output voltage calculation formula = $10^{(D+Vol_Gain)/20} \times 3.5 \times \text{Hard clipping threshold} \times \text{Output_Gain (Vp)}$
 Noted : There is -2dB at Digital Filter. The DAC 10.9dB has been included the -2dB.
 So, the hard clipping only work when threshold < -2dB.

Address	BITS	Name	Description
0x07	2:0	D_SPK_GAIN[2:0]	Class-D output gain 000: 2.0x 001: 2.5x 010: 3.618x 011: 4.000x 100: 4.444x 101: 5.00x 110: 5.614x 111: 6.316x

Master Volume Gain

Address	BITS	Name	Equation																								
0x20	10:0	MS_VOL[10:0]	<p>Equation: $24\text{dB} - (\text{Dec} \times 0.0625)$ Range: 24dB (0X000) to mute (0x7ff) Ex: 10dB, Hex = 0xE0 Dec = 224 Gain = $24\text{dB} - (224 \times 0.0625) = 10\text{dB}$</p> <table border="1"> <thead> <tr> <th>Gain</th> <th>Dec</th> <th>Hex</th> </tr> </thead> <tbody> <tr> <td>24dB</td> <td>0</td> <td>0x00</td> </tr> <tr> <td>10dB</td> <td>224</td> <td>0XE0</td> </tr> <tr> <td>.</td> <td>.</td> <td>.</td> </tr> <tr> <td>.</td> <td>.</td> <td>.</td> </tr> <tr> <td>0dB</td> <td>384</td> <td>0x180</td> </tr> <tr> <td>.</td> <td>.</td> <td>.</td> </tr> <tr> <td>.</td> <td>.</td> <td>.</td> </tr> </tbody> </table>	Gain	Dec	Hex	24dB	0	0x00	10dB	224	0XE0	0dB	384	0x180
Gain	Dec	Hex																									
24dB	0	0x00																									
10dB	224	0XE0																									
.	.	.																									
.	.	.																									
0dB	384	0x180																									
.	.	.																									
.	.	.																									

Volume Ramp Up/Down Time

00: 1 step in every sample.

01: mute → -40dB, every sample with 1 step. -40dB → 24dB, 2 sample with 1 step.

10: mute → -40dB, 2 sample with 1 step. -40dB → 24dB, 4 sample with 1 step.

Others: mute → -40dB, 4 sample with 1 step. -40dB → 24dB, 8 sample with 1 step.

Address	BITS	Name	Description
0x0A	1:0	VOL_RAMP_MODE[1:0]	00: 1 step in every sample. 01: mute → -40dB, every sample with 1 step. -40dB → 24dB, 2 sample with 1 step. 10: mute → -40dB, 2 sample with 1 step. -40dB → 24dB, 4 sample with 1 step. Others: mute → -40dB, 4 sample with 1 step. -40dB → 24dB, 8 sample with 1 step.

Hard Clip Function

To clip the signal with different threshold, operate in time domain.

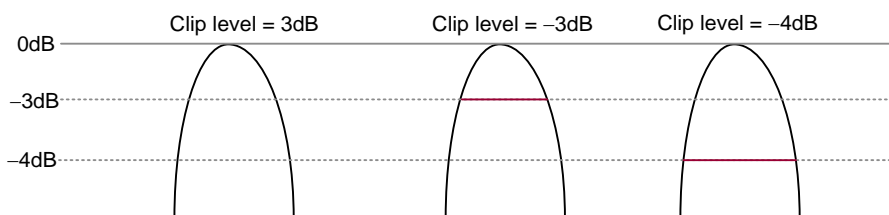

Address	BITS	Name	Description
0x06	0	HARD_CLIP_EN	0: Disable hard clip (default) 1: Enable hard clip
0x27	10:0	HARD_CLIP_TH[10:0]	Hard Clip Threshold for Hard clip, when threshold > 0, there is no any clipping effect happened. 11'h180: 0dB 0.0625db per step Noted: Due to there is -2dB at digital filter, so hard clipping only works when threshold < -2dB.

DC Protection Function

It is to use to protect the loudspeaker, when there are some DC exists at the output. The method is to detect DC at final stage (PWM), calculate the difference of the PWM and a sinc filter to decide the DC level. The IC will shut down when detect the DC.

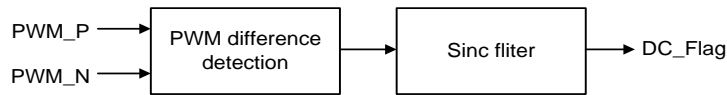

Address	BITS	Name	Description
0x14	7:4	Reserved	
	3:2	DC_TH[1:0]	DC threshold for DC detection 00: No available 01: 12.5% 10: 18.75% (default) 11: 25%
	1	DC_TIME_SEL	Detection time 0: 342ms (default) 1: 684ms
	0	DC_EN	0: DC protection disable 1: DC protection enable (default)

Compensate Filter

Compensation filter is purpose to compensate internal gain from DAC, this filter can also compensate the frequency response affected by LC filter, the recommended setting will base on different application circuit to fit the curve.

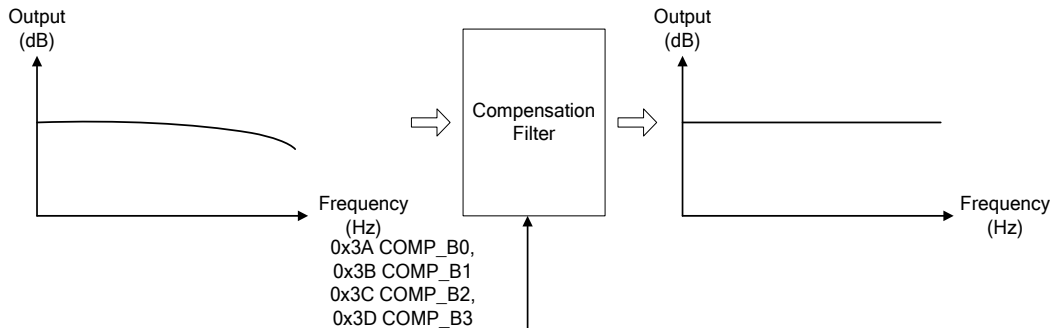

Compensate	Description									
Compensate	B0, B1, B2, B3: Compensate coefficient									
Gain										
Gain	0.1dB	0.2dB	0.3dB	0.4dB	0.5dB	0.6dB	0.7dB	0.8dB	0.9dB	1dB
Coefficient										
B3	00000	1FFFF	00003	00006	00005	00005	00004	00002	00002	00008
B2	0000E	0001E	00022	00026	0003A	00048	0005C	00073	00081	0007F
B1	1FFA1	1FF43	1FEDE	1FE79	1FE19	1FDB1	1FD51	1FCE9	1FC81	1FC14
B0	080A0	0813E	081FF	082C0	0835A	0840F	084A8	0854D	08602	086E0

Address	BITS	Name	Description
0x06	6	COMP_EN	0: Compensation filter disable (default) 1: Compensation filter enable (Not available for 96kHz and 192kHz sampling rate)
0x3A	23:17	Reserved	Compensate B0 coefficient
	16:0	COMP_B0	
0x3B	23:17	Reserved	Compensate B1 coefficient
	16:0	COMP_B1	
0x3C	23:17	Reserved	Compensate B2 coefficient
	16:0	COMP_B2	
0x3D	23:17	Reserved	Compensate B3 coefficient
	16:0	COMP_B3	

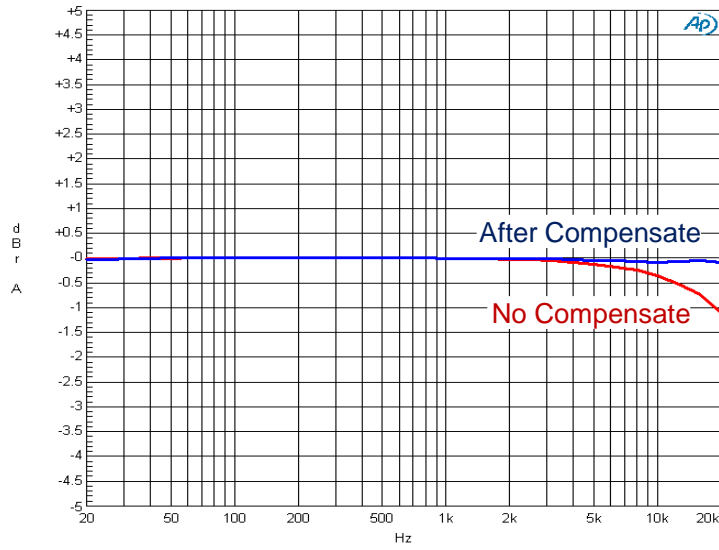

TDM

The RT9120M supports TDM format, which maximum output can reach 16Ch.

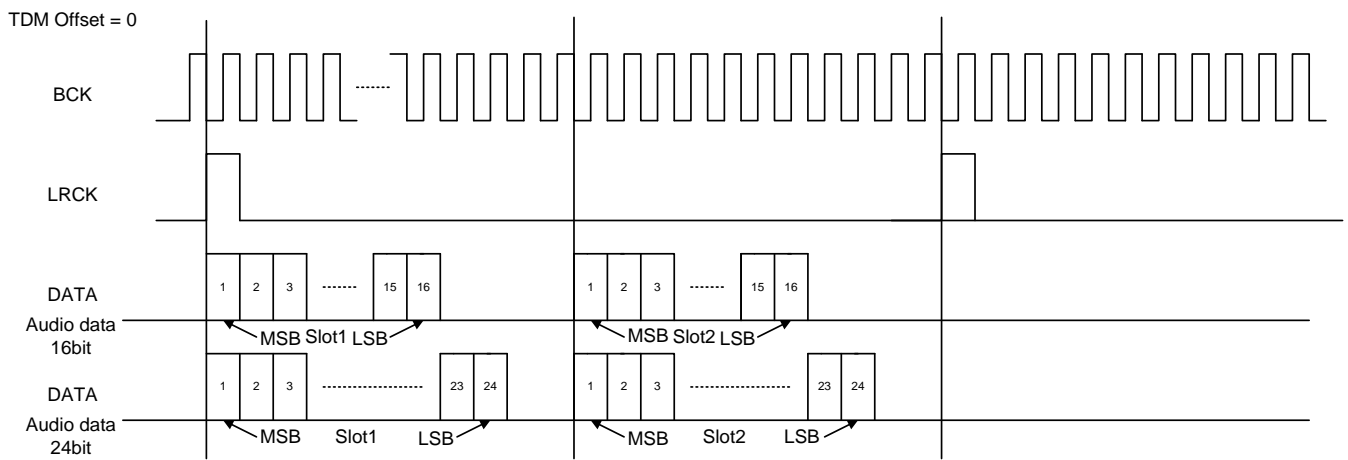
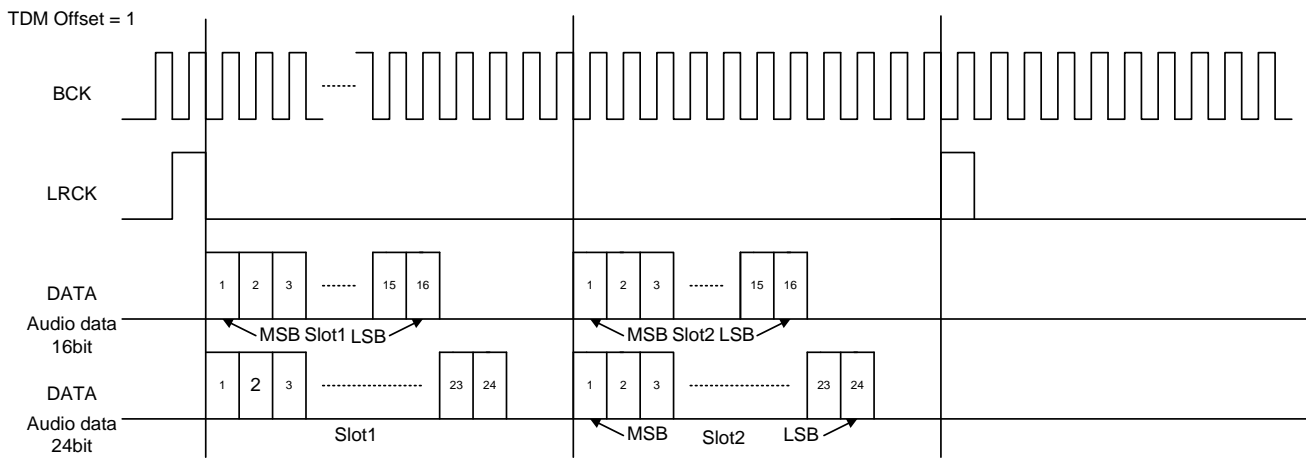

Address	BITS	Name	Description
0xA0	7:3	Reserved	
	2	DATAO_PD	Prohibited
	1	TDM_OFFSET	TDM offset selection 0: Without offset 1: 1 bit clock offset (default)
	0	TDM_EN	0: TDM disable TDM application (default) 1: TDM enable
0xA1	7:6	Reserved	
	5:0	TDM_RX_LOC_L	TDM start receiving location select for left channel (reg*8 + offset) 000000: Start from 0+offset (default) 000001: Start from 8+offset ... 111100: Start from 480+offset 111101: Start from 488+offset 111110: Not available 111111: Not available
0xA2	7:6	Reserved	
	5:0	TDM_RX_LOC_R	TDM start receiving location select for left channel (reg*8 + offset) 000000: Start from 0+offset 000001: Start from 8+offset ... 111100: Start from 480+offset 111101: Start from 488+offset 111110: Not available 111111: Not available 000100: Start from 32+offset (default)
0xA3	7:6	Reserved	
	5:0	TDM_TX_LOC_L	TDM start transmitting location select for left channel (reg*8 + offset) 000000: Start from 0+offset (default) 000001: Start from 8+offset ... 111100: Start from 480+offset 111101: Start from 488+offset 111110: Not available 111111: Not available
0xA4	7:6	Reserved	
	5:0	TDM_TX_LOC_R	TDM start transmitting location select for right channel (reg*8 + offset) 000000: Start from 0+offset 000001: Start from 8+offset ... 111100: Start from 480+offset 111101: Start from 488+offset 111110: Not available 111111: Not available 000100: Start from 32+offset (default)

Example

1. Set the 0xA0, Bit[0] to 1
2. Set the 0x03, Bit[7:6] to 00
3. Use the below setting

Noted: The RT9120M has SDO output, which can output the I²S data and TDM data to SOC side for receiving use, so if the receiving not use, the 0xA3, and 0xA4 can keep the default setting.

If output is 16Ch, Sampling Rate is 48kHz								
Output Ch	Ch1, Ch2	Ch3, Ch4	Ch5, Ch6	Ch7, Ch8	Ch9, Ch10	Ch11, Ch12	Ch13, Ch14	Ch15, Ch16
0xA1	Set to 0x00	Set to 0x06	Set to 0x0C	Set to 0x12	Set to 0x18	Set to 0x1E	Set to 0x24	Set to 0x2A
0xA2	Set to 0x03	Set to 0x09	Set to 0x0F	Set to 0x15	Set to 0x1B	Set to 0x21	Set to 0x27	Set to 0x2D
0xA3	Set to 0x00	Set to 0x06	Set to 0x0C	Set to 0x12	Set to 0x18	Set to 0x1E	Set to 0x24	Set to 0x2A
0xA4	Set to 0x03	Set to 0x09	Set to 0x0F	Set to 0x15	Set to 0x1B	Set to 0x21	Set to 0x27	Set to 0x2D

If output is 8Ch, Sampling Rate is 96kHz				
Output Ch	Ch1, Ch2	Ch3, Ch4	Ch5, Ch6	Ch7, Ch8
0xA1	Set to 0x00	Set to 0x06	Set to 0x0C	Set to 0x12
0xA2	Set to 0x03	Set to 0x09	Set to 0x0F	Set to 0x15
0xA3	Set to 0x00	Set to 0x06	Set to 0x0C	Set to 0x12
0xA4	Set to 0x03	Set to 0x09	Set to 0x0F	Set to 0x15

If output is 4Ch, Sampling Rate is 192kHz		
Output Ch	Ch1, Ch2	Ch3, Ch4
0xA1	Set to 0x00	Set to 0x06
0xA2	Set to 0x03	Set to 0x09
0xA3	Set to 0x00	Set to 0x06
0xA4	Set to 0x03	Set to 0x09

PBTL Function

It can be configured by the hardware, also need to change the software setting.

The Input signal, can be configured by the input mixer, from register 0x30 to configure the input signal. The default signal for the PBTL is from 0x30 L channel signal.

Address	BITS	Name	Description
0x05	3	D_PBTL	0: BTL 1: PBTL

Address	BITS	Name	Description
0x30	16:0	CH1_IN_MIX_0	u[23:17], mix_0[16:0] u: Unused
0x31	16:0	CH1_IN_MIX_1	u[23:17], mix_1[16:0] u: Unused

Mono PBTL Application Circuit

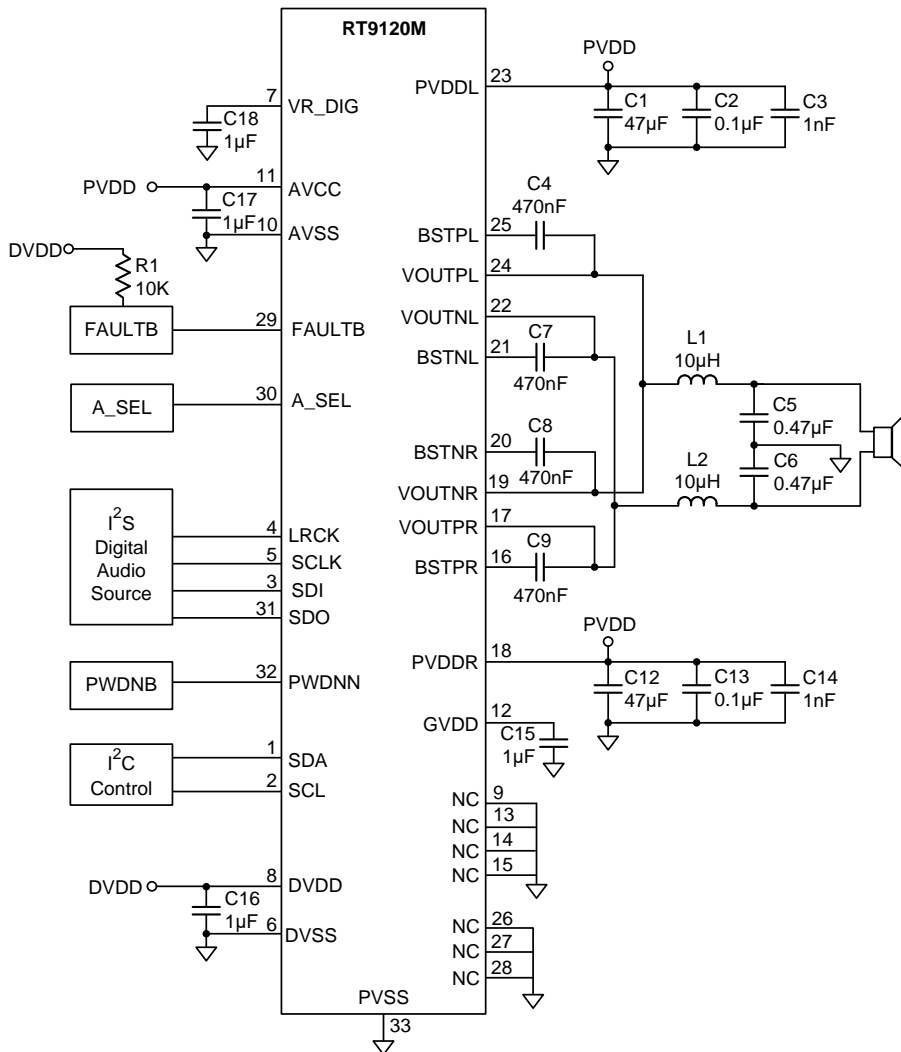

Mono Configuration

To use the mono configuration, It can be configured by register setting.

Address	BITS	Name	Description
0x08	7	D_LPFR_EN	Enable DAC RCH LPF 0: Disable 1: Enable (default)
	6	D_LPFL_EN	Enable DAC LCH LPF 0: Disable 1: Enable (default)
	5	D_EN_RCH_PWR	RCH PWR stage enable 0: Disable 1: Enable (default)
	4	D_EN_LCH_PWR	LCH PWR stage enable 0: Disable 1: Enable (default)
	3	D_DAC_RCH_EN	Enable DAC_RCH 0: Disable 1: Enable (default)
	2	D_DAC_LCH_EN	Enable DAC LCH 0: Disable 1: Enable (default)
	1	D_SPK_RCH_EN	Enable Class-D RCH SPK 0: Disable 1: Enable (default)
	0	D_SPK_LCH_EN	Enable Class-D LCH SPK 0: Disable 1: Enable (default)

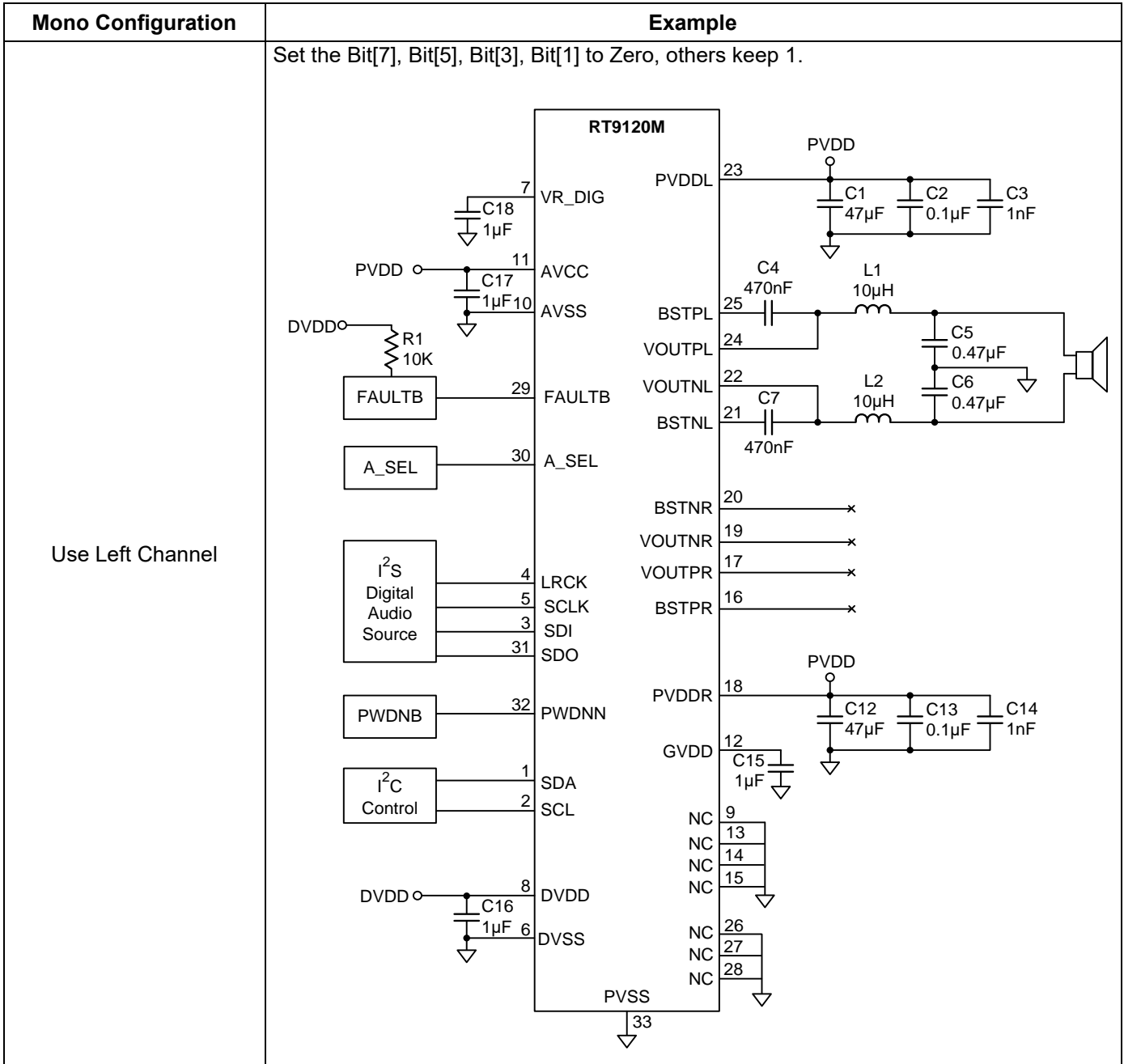

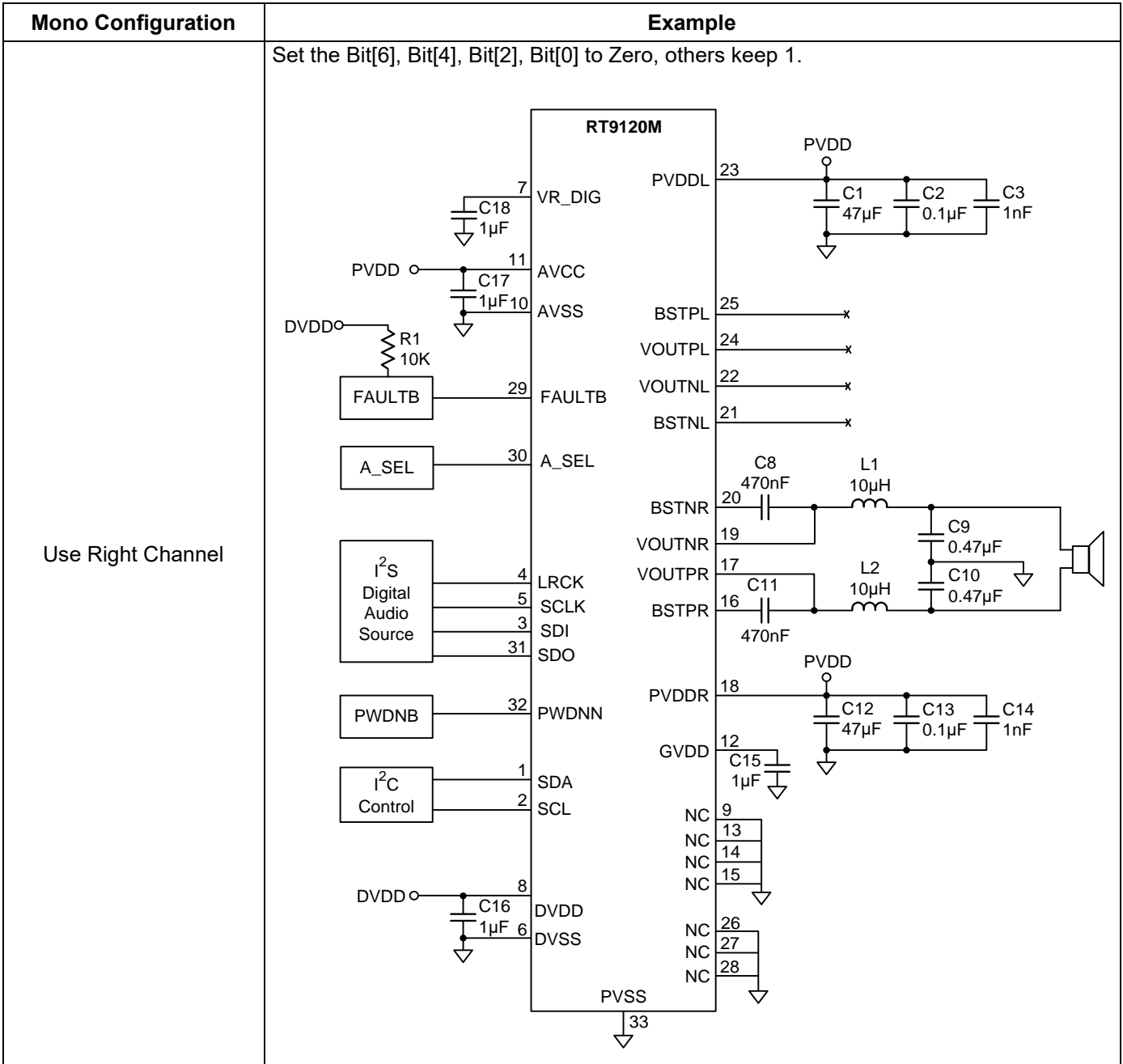

Protection Behavior

If the protection behavior happened, the IC will automated detect, the error condition can be checked by the register or FAULTB pin.

Protection Flag

Address	BITS	Name	Description
0x10	7	Reserved	
	6	DC_ERR	DC flag report 0: No DC error (default) 1: DC error
	5	SCLK_ERR	0: No SCLK error (default) 1: SCLK error, write 0 to clear flag
	4	LRCK_ERR	0: No LRCK clock error (default) 1: LRCK clock error, write 0 to clear flag
	3	OC_ERR	0: No OC error (default) 1: OC, write 0 to clear flag
	2	OV_ERR	0: No OV error (default) 1: OV, write 0 to clear flag
	1	OT_ERR	0: No OT error (default) 1: OT, write 0 to clear flag
	0	UV_ERR	0: No UV error (default) 1: UV, write 0 to clear flag

Protection Type

Protection	Auto Recovery	Shutdown Amp (Latch Type)	Fault Pin Pull Low
DC Protection	No	Yes	Yes
SCLK ERROR	Yes. The default setting is Auto recovery.	Yes, it can be configured by the 0x12 bit[5]	Yes, but the MASK can be configured by the 0x11 bit[5]
LRCK ERROR	Yes. The default setting is Auto recovery.	Yes, it can be configured by the 0x12 bit[4]	Yes, but the MASK can be configured by the 0x11 bit[4]
OC ERROR	No	Yes	Yes
OV ERROR	Yes. The default setting is Auto recovery.	Yes, it can be configured by the 0x12 bit[2]	Yes, but the MASK can be configured by the 0x11 bit[2]
OT ERROR	Yes. The default setting is Auto recovery.	Yes, it can be configured by the 0x12 bit[1]	Yes, but the MASK can be configured by the 0x11 bit[1]
UV ERROR	Yes. The default setting is Auto recovery.	Yes, it can be configured by the 0x12 bit[0]	Yes, but the MASK can be configured by the 0x11 bit[0]

When protection happened, there are 2 types of the protection behavior can be use.

1. Latch type: Will shut down the AMP directly.
2. Auto recovery type: The AMP will enter the auto recovery mode, until the protection behavior stop, the AMP will continued to work.
3. The DC, and OC protection only has the latch type.

Fault Behavior Type Select

If the protection behavior happened, the IC will automate detect, there are some error type can be configured by below list.

Address	BITS	Name	Description
0x12	5	SCLK_ERROR_FAULT_TYPE	Fault behavior type select. 0: Auto recovery (default) 1: Latch
	4	LRCK_ERROR_FAULT_TYPE	Fault behavior type select. 0: Auto recovery (default) 1: Latch
	3	OC_ERROR_FAULT_TYPE	Only latch type
	2	OV_ERROR_FAULT_TYPE	Fault behavior type select. 0: Auto recovery (default) 1: Latch
	1	OT_ERROR_FAULT_TYPE	Fault behavior type select. 0: Auto recovery (default) 1: Latch
	0	UV_ERROR_FAULT_TYPE	Fault behavior type select. 0: Auto recovery (default) 1: Latch

Fault Mask

Address	BITS	Name	Description
0x11	5	SCLK_ERROR_mask	Fault mask for 0x10 SCLK error
	4	LRCK_ERROR_mask	Fault mask for 0x10 LRCK error
	3	OC_ERROR_mask	Fault mask for 0x10 OC error
	2	OV_ERROR_mask	Fault mask for 0x10 OV error
	1	OT_ERROR_mask	Fault mask for 0x10 OT error
	0	UV_ERROR_mask	Fault mask for 0x10 UV error

Thermal Considerations

The junction temperature should never exceed the absolute maximum junction temperature $T_{J(MAX)}$, listed under Absolute Maximum Ratings, to avoid permanent damage to the device. The maximum allowable power dissipation depends on the thermal resistance of the IC package, the PCB layout, the rate of surrounding airflow, and the difference between the junction and ambient temperatures. The maximum power dissipation can be calculated using the following formula:

$$P_{D(MAX)} = (T_{J(MAX)} - T_A) / \theta_{JA}$$

where $T_{J(MAX)}$ is the maximum junction temperature, T_A is the ambient temperature, and θ_{JA} is the junction-to-ambient thermal resistance.

For continuous operation, the maximum operating junction temperature indicated under Recommended Operating Conditions is 150°C. The junction-to-ambient thermal resistance, θ_{JA} , is highly package dependent. For a VQFN-32L 5x5 package, the thermal resistance, θ_{JA} , is 27.5°C/W on a standard JEDEC 51-7 high effective- thermal-conductivity four-layer test board. The maximum power dissipation at $T_A = 25^\circ\text{C}$ can be calculated as below:

$$P_{D(MAX)} = (150^\circ\text{C} - 25^\circ\text{C}) / (27.5^\circ\text{C/W}) = 3.63\text{W for a VQFN-32L 5x5 package.}$$

The maximum power dissipation depends on the operating ambient temperature for the fixed $T_{J(MAX)}$ and the thermal resistance, θ_{JA} . The derating curves in Figure 3 allows the designer to see the effect of rising ambient temperature on the maximum power dissipation.

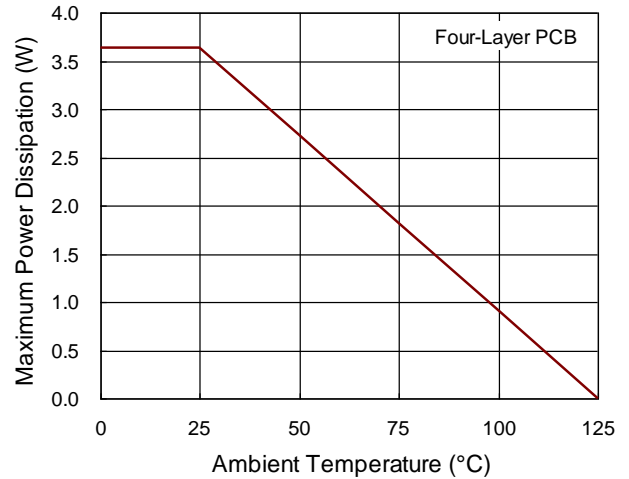
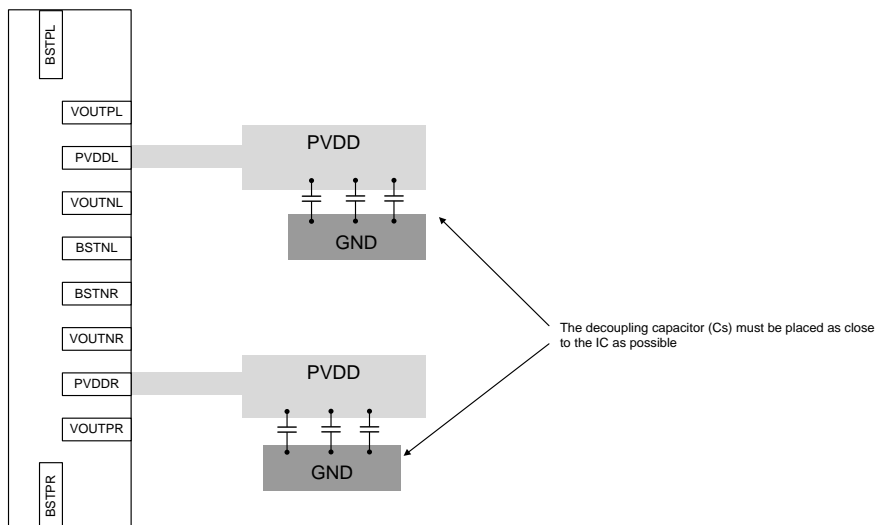

Figure 3. Derating Curve of Maximum Power Dissipation

Layout Guide

Place the decoupling capacitors as close as possible to the PVCC and GND, then use shortest trace to link these capacitors, and use more vias for GND link to GND layer to reduce parasitic inductance and resistance. The trace width is 30mil at least.



The VR_DIG, and GVDD decoupling capacitors must be placed as close to the IC as possible.

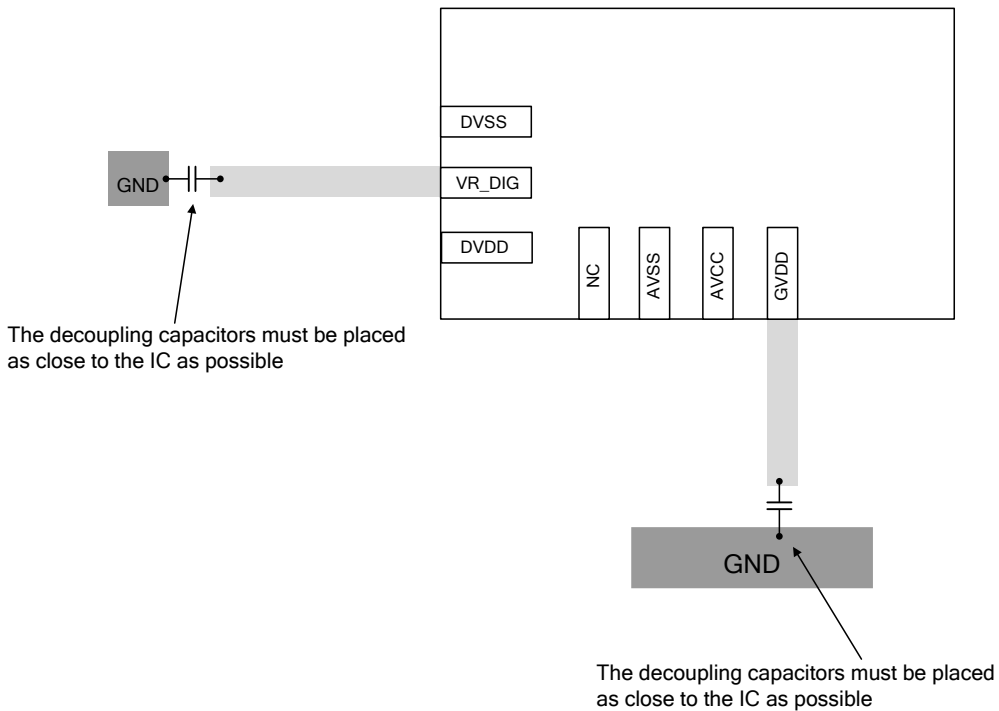

Place the decoupling capacitors as close as possible to the DVDD and DVSS Pin, AVCC and AVSS Pin for achieving good audio quality, the trace width of DVDD is 6mil at least and the trace width of AVCC is 30mil at least

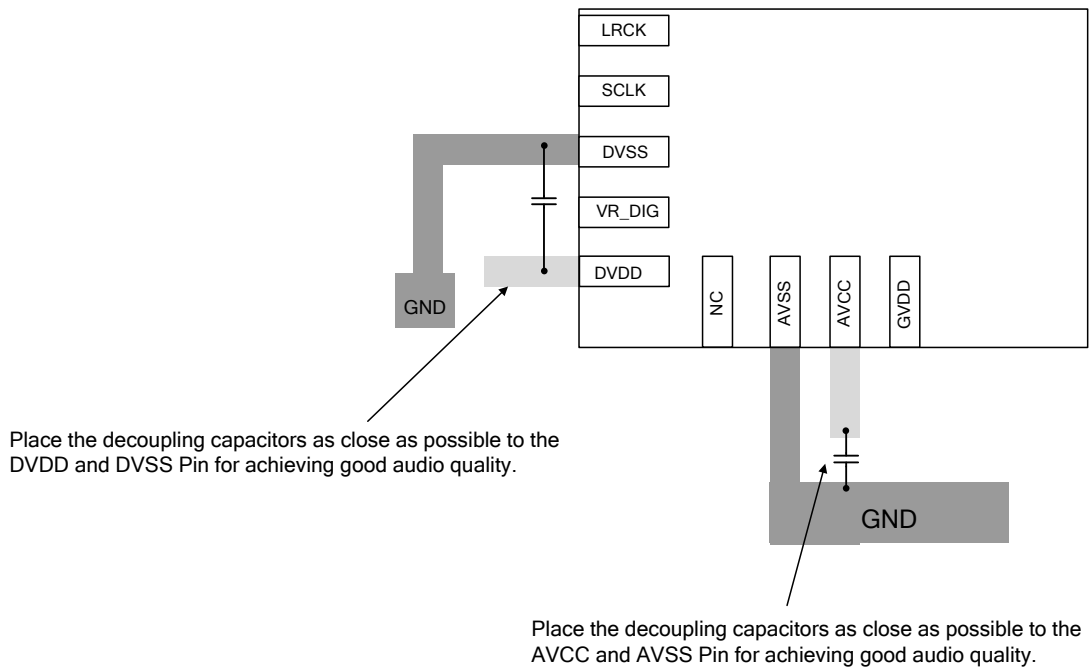

The traces of VOUTPL VOUTNL VOUTPR and VOUTNR should be kept equal width and length respectively, and Bootstrap supply to Lx capacitance required close to the IC.

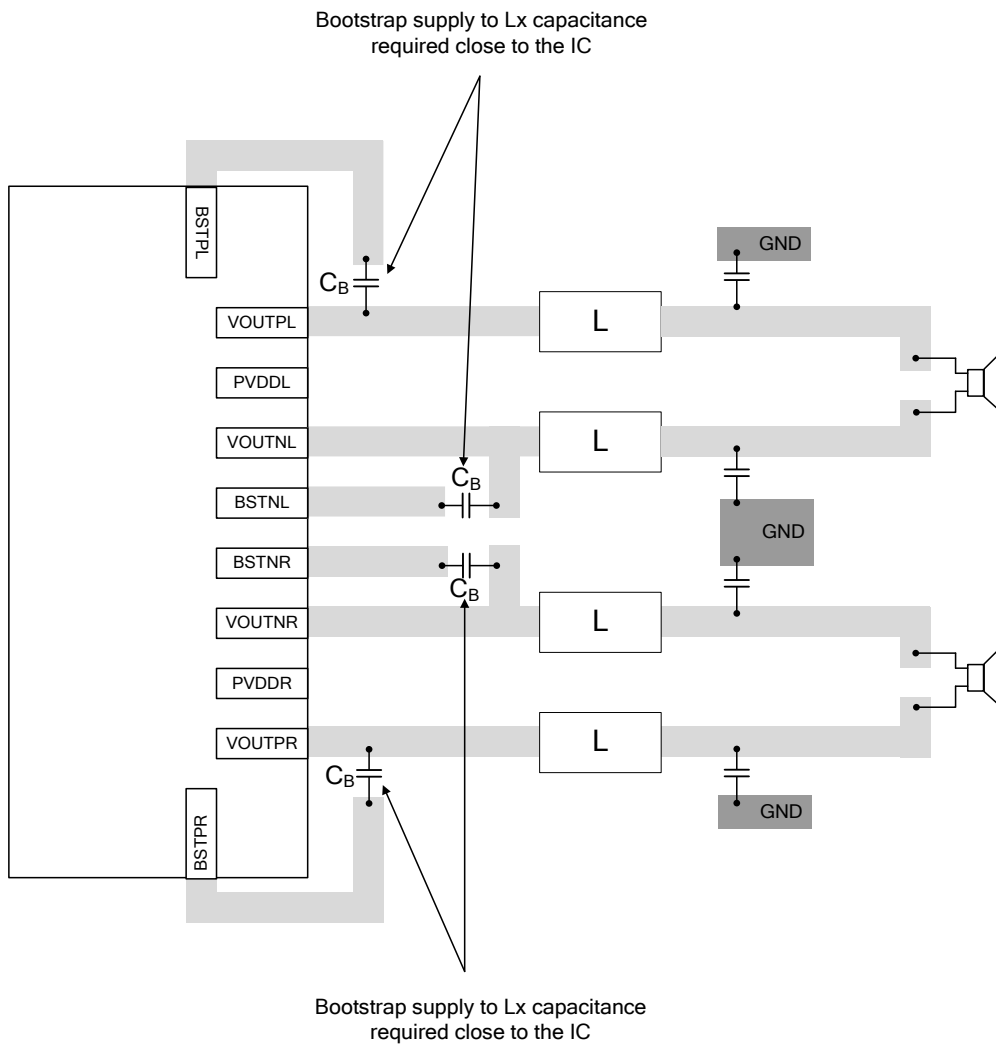

If possible, coplanar ground fill on both sides for differential pair of speaker out shielding.

Register Map

ADDR	Byte	RegName	BITS	R/W	Name	Description	Default
0x00	1	DEV_ID	7:0	R	DEVICE_ID[7:0]		8'h10
0x01	1	I2S_CLK_FMT	7:4	R/W	SR_MODE[2:0]	Sampling rate report 0000: 8kHz 0001: 11.025/12kHz 0010: 16kHz 0011: 22.05/24kHz 0100: 32kHz 0101: 44.1/48kHz (default) 0110: 88.2/96kHz 0111: 192kHz Others: Not supported/SCLK loss/LRCK loss	4'b0101
			3:0	R/W	BCK_MODE[2:0]	BCK mode report 0000: BCK = 32fs 0001: BCK = 48fs 0010: BCK = 64fs (default) 0011: BCK = 96fs 0100: BCK = 128fs 0101: BCK = 192fs 0110: BCK = 256fs 0111: BCK = 384fs 1000: BCK = 512fs Others: Not supported/SCLK loss Noted: For the 48fs, 96fs, 192fs, 384fs, 512fs, please set 0xF8 bit[6] to 0.	4'b0010
0x02	1	I2S_DATA_FMT	7	R	Reserved	Prohibited	1'b0
			6	R	Reserved	Prohibited	1'b0
			5	R	Reserved	Prohibited	1'b0
			4	R/W	DSP_M_A_S	DSP mode A select, active with AUD_FMT = 2'b11 (DSP mode) 0: DSP mode A (default) 1: DSP mode B	1'b0
			3:2	R/W	AUD_FMT	00: I ² S (default) 01: Left Justify 10: Right Justify 11: DSP mode	2'b00
			1:0	R/W	AUD_BITS	00: 16bits I ² S 01: 20bits I ² S 10: 24bits I ² S (default) Others: No define	2'b10

ADDR	Byte	RegName	BITS	R/W	Name	Description	Default
0x03	1	I2S_DATA_WL	7:6	R/W	SCLK_DEG_SEL[1:0]	SCLK deglitch time selection 00: No deglitch 01: 1T sync 10: 2T deglitch 11: 3T deglitch (default)	2'b11
			5:0	R/W	AUD_WL	Audio slot length 0 to 16: 16bits ... 32: 32bits (default) 33 to 63: Not supported	6'd32
0x04	1	SDIO_SEL	7:6	R	Reserved		2'b00
			5:4	R/W	SDO_SEL[1:0]	00: No output (default) 01: Interface output 10: Final output 11: Peak level detect result	2'b00
			3:2	R/W	CH1_SI[1:0]	00: SDIN-L to CH1 (default) 01: SDIN-R to CH1 1X: 0 to CH1	2'b00
			1:0	R/W	CH2_SI[1:0]	00: SDIN-L to CH2 (default) 01: SDIN-R to CH2 (default) 1X: 0 to CH2	2'b01
0x05	1	SYS_CTL	7	R/W	SR_AUTO_DET	Prohibited	1'b1
			6	R/W	SHUTDOWN	0: Turn on 1: Shut down (default)	1'b1
			5:4	R	Reserved		2'b00
			3	R/W	D_PBTL	0: BTL (default) 1: PBTL	1'b0
			2	R/W	D_SPK_VT_FREQ	PWM frequency 0: 400kHz (default) 1: 800kHz	1'b0
			1	R/W	DIS_A_SEL_PU	Prohibited	1'b0
			0	R/W	dSR_DIV_SEL	Prohibited	1'b0

ADDR	Byte	RegName	BITS	R/W	Name	Description	Default
0x06	1	DIG_BLK_EN	7	R/W	Reserved		1'b0
			6	R/W	COMP_EN	0: Compensation filter disable (default) 1: Compensation filter enable (not available in 96k & 192kHz Sampling Rate)	1'b0
			5	R/W	HPF_EN	0: High-Pass filter disable 1: High-Pass filter enable (default)	1'b1
			4	R/W	TFC_EN	Thermal fold back control enable 0: Disable (default) 1: Enable	1'b0
			3	R/W	DRC_PEAK	DRC mode selection 0: RMS mode 1: Peak mode (default)	1'b1
			2	R/W	DRC_EN	DRC enable 0: Disable (default) 1: Enable	1'b0
			1	R/W	DRC_N_EN	DRC noise gate enable 0: Disable (default) 1: Enable	1'b0
			0	R/W	HARD_CLIP_EN	Hard clip enable 0: Disable (default) 1: Enable	1'b0
0x07	1	SPK_GAIN	7:3	R	Reserved		5'b00000
			2:0	R/W	D_SPK_GAIN[2:0]	Class-D output gain 000: 2.000x (6dB) 001: 2.500x (8dB) 010: 3.168x (10dB) 011: 4.000x (12dB) 100: 4.444x (13dB) (default) 101: 5.000x (14dB) 110: 5.614x (15dB) 111: 6.316x (16dB)	3'b100

ADDR	Byte	RegName	BITS	R/W	Name	Description	Default
0x08	1	INTER_PWR_CTRL	7	R/W	D_LPFR_EN	Enable DAC RCH LPF 0: Disable 1: Enable (default)	1'b1
			6	R/W	D_LPFL_EN	Enable DAC LCH LPF 0: Disable 1: Enable (default)	1'b1
			5	R/W	D_EN_RCH_PWR	RCH PWR stage enable 0: Disable 1: Enable (default)	1'b1
			4	R/W	D_EN_LCH_PWR	LCH PWR stage enable 0: Disable 1: Enable (default)	1'b1
			3	R/W	D_DAC_RCH_EN	Enable DAC_RCH 0: Disable 1: Enable (default)	1'b1
			2	R/W	D_DAC_LCH_EN	Enable DAC LCH 0: Disable 1: Enable (default)	1'b1
			1	R/W	D_SPK_RCH_EN	Enable Class-D RCH SPK 0: Disable 1: Enable (default)	1'b1
			0	R/W	D_SPK_LCH_EN	Enable Class-D LCH SPK 0: Disable 1: Enable (default)	1'b1
0x09	2	PWM_SS_OPT	7	R/W	D_FSS_EN	Spread spectrum enable 0: Disable (default) 1: Enable	1'b0
			6	R/W	PWM_MODEWHITE	Noise select 0: Pink noise (default) 1: White noise	1'b0
			5	R/W	PWM_SELCOEF	Pink noise coefficient This will affect the noise amplitude for spread spectrum signal, not recommended to modify it. 0: 1/2 (default) 1: 1/4	1'b0
			4	R/W	PWM_NOISE_EN	Add noise to TRI_GEN 0: Disable (default) 1: Enable	1'b0
			3:2	R/W	D_NOISE_AMP[1:0]	Noise amplitude for SSC	2'b00
			1:0	R/W	D_FSS_AMP[1:0]	Spread spectrum frequency variation amplitude 00: 20kHz 01: 40kHz (default) 10: 40kHz 11: 60kHz	2'b01

ADDR	Byte	RegName	BITS	R/W	Name	Description	Default
0x0A	1	VOL_RAMP	7:6	R	Reserved		2'b00
			5	R/W	CH2_MUTE	0: Unmute (default) 1: CH2 soft mute	1'b0
			4	R/W	CH1_MUTE	0: Unmute (default) 1: CH1 soft mute	1'b0
			3	R/W	SKIP_RAMP	Skip volume ramp	1'b0
			2	R	Reserved		1'b0
			1:0	R/W	VOL_RAMP_MODE [1:0]	Volume Slew step control 00: 1 step in every sample 01: mute → -40dB, every sample with 1 step. -40dB → 24dB, 2 sample with 1 step. (default) 10: mute → -40dB, 2 sample with 1 step. -40dB → 24dB, 4 sample with 1 step. (default) Others: Mute → -40dB, 4 sample with 1 step. -40dB → 24dB, 8 sample with 1 step.	2'b01
0x0B	1	TFC_CTRL	7:6	R	Reserved		2'b00
			5	R	D_TFC_UPBOUN_FLAG	Prohibited	1'b0
			4	R	D_TFC_LOWBOUN_FLAG	Prohibited	1'b0
			3:2	R/W	TFC_TH	Thermal fold back active threshold 00: Temp 110°C (default) 01: Temp 120°C 10: Temp 130°C 11: Temp 140°C	2'b00
			1:0	R/W	TFC_RATE	Thermal fold back attack/release rate 00: 0.0625dB/50ms (default) 01: 0.0625dB/100ms 10: 0.0625dB/200ms 11: 0.0625dB/400ms	2'b00
0x0C	1	Reserved	7:0	R/W	Reserved	Prohibited	8'h00

ADDR	Byte	RegName	BITS	R/W	Name	Description	Default
0x10	1	ERR_RPT	7	R/W	MEM_BIST_ERR	Prohibited	1'b0
			6	R	DC_ERR	DC flag report 0: No DC error (default) 1: DC error	1'b0
			5	R/W	SCLK_ERR	0: No SCLK error (default) 1: SCLK error, write 0 to clear flag	1'b0
			4	R/W	LRCK_ERR	0: No LRCK clock error (default) 1: LRCK clock error, write 0 to clear flag	1'b0
			3	R/W	OC_ERROR	0: No OC error (default) 1: OC, write 0 to clear flag	1'b0
			2	R/W	OV_ERROR	0: No OV error (default) 1: OV, write 0 to clear flag	1'b0
			1	R/W	OT_ERROR	0: No OT error (default) 1: OT, write 0 to clear flag	1'b0
			0	R/W	UV_ERROR	0: No UV error (default) 1: UV, write 0 to clear flag	1'b0
0x11	1	ERR_MASK	7:6	R	Reserved		2'b00
			5	R/W	SCLK_ERROR_MASK	Fault mask for 0x02 SCLK error 0: Not mask 1: Mask (default)	1'b1
			4	R/W	LRCK_ERROR_MASK	Fault mask for 0x02 LRCK error 0: Not mask 1: Mask (default)	1'b1
			3	R/W	OC_ERROR_MASK	Fault mask for 0x02 OC error 0: Not mask (default) 1: Mask	1'b0
			2	R/W	OV_ERROR_MASK	Fault mask for 0x02 OV error 0: Not mask (default) 1: Mask	1'b0
			1	R/W	OT_ERROR_MASK	Fault mask for 0x02 OT error 0: Not mask (default) 1: Mask	1'b0
			0	R/W	UV_ERROR_MASK	Fault mask for 0x02 UV error 0: Not mask (default) 1: Mask	1'b0

ADDR	Byte	RegName	BITS	R/W	Name	Description	Default
0x12	1	'ERR_TYPE	7:6	R	Reserved		2'b00
			5	R/W	SCLK_ERROR_FAULT_TYPE	Fault behavior type select. 0: Auto recovery (default) 1: Latch	1'b0
			4	R/W	LRCK_ERROR_FAULT_TYPE	Fault behavior type select. 0: Auto recovery (default) 1: Latch	1'b0
			3	R/W	OC_ERROR_FAULT_TYPE	Only support latch type	1'b1
			2	R/W	OV_ERROR_FAULT_TYPE	Fault behavior type select. 0: Auto recovery (default) 1: Latch	1'b0
			1	R/W	OT_ERROR_FAULT_TYPE	Fault behavior type select. 0: Auto recovery (default) 1: Latch	1'b0
			0	R/W	UV_ERROR_FAULT_TYPE	Fault behavior type select. 0: Auto recovery (default) 1: Latch	1'b0
0x13	1	AUTO_RCVR	7:6	R	Reserved		2'b0
			5	R/W	FAULT_B_TYPE	0: Recovery type (default) 1: Latch type	1'b0
			4	R/W	PROT_PWR_PL_EN	Prohibited	1'b1
			3:0	R/W	Prohibited	Prohibited	4'b0010
0x14	1	DC_PROT	7:4	R	Reserved		4'b0000
			3:2	R/W	DC_TH[1:0]	DC threshold for DC detection 00: No available 01: 12.5% 10: 18.75% (default) 11: 25%	2'b10
			1	R/W	DC_TIME_SEL	Detection time 0: 342ms (default) 1: 684ms	1'b0
			0	R/W	DC_EN	DC protection enable 0: Disable 1: Enable (default)	1'b1
0x15	1	Reserved_15	7:0	R/W	Reserved	Prohibited	8'h00

ADDR	Byte	RegName	BITS	R/W	Name	Description	Default
0x20	2	MS_VOL	15:11	R	Reserved	Prohibited	5'b00000
			10:0	R/W	MS_VOL[10:0]	Master volume control 11'h000: 24dB 11'h180: 0dB 11'h7FF: mute (default) 0.0625dB per step	11'h7FF
0x21	2	CH1_VOL	15:11	R	Reserved	Prohibited	5'b00000
			10:0	R/W	CH1_VOL[10:0]	CH1 volume control 11'h000: 24dB 11'h180: 0dB (default) 11'h7FF: mute 0.0625dB per step	11'h180
0x22	2	CH2_VOL	15:11	R	Reserved	Prohibited	5'b00000
			10:0	R/W	CH2_VOL[10:0]	CH2 volume control 11'h000: 24dB 11'h180: 0dB (default) 11'h7FF: mute 0.0625dB per step	11'h180
0x23	2	DRC_TH	15:11	R	Reserved	Prohibited	5'b00000
			10:0	R/W	DRC_TH	DRC threshold 11'h000: 0dB (default) 11'h180: -24dB 11'h67E: -103.875dB 11'h67F~11'h7FF: Not available 0.0625dB per step	11'h000
0x24	2	DRC_RATIO	15:8	R	Reserved	Prohibited	8'h00
			7:0	R/W	DRC_RATIO	DRC compress ratio 8'h00: No compression 8'h80~8'hFF: Full compression 1/128 per step	8'h80
0x25	2	DRC_OFFSET	15:11	R	Reserved	Prohibited	5'b00000
			10:0	R/W	DRC_OFFSET	DRC make up gain (Offset) 11'h000: 24dB 11'h180: 0dB (default) 11'h7FE: -103.9375dB 11'h7FF: Not available 0.0625dB per step	11'h180

ADDR	Byte	RegName	BITS	R/W	Name	Description	Default
0x26	2	DRC_NG_TH	15:11	R	Reserved	Prohibited	5'b00000
			10:0	R/W	DRC_NG_TH	Noise gate threshold 11'h000: 0dB 11'h180: -24dB 11'h640: -100dB (default) 11'h67E: -103.875dB 11'h67F~11'h7FF: Not available 0.0625dB per step	11'h640
0x27	2	HARD_CLIP_TH	15:11	R	Reserved	Prohibited	5'b00000
			10:0	R/W	HARD_CLIP_TH [10:0]	Hard Clip Threshold when HARD_CLIP_EN = 1 > 0dB is not allowable for hard clip threshold setting 11'h180: 0dB (default) 0.0625db per step	11'h180
0x30	3	CH1_IN_MIX_0	23:17	R	Reserved	Prohibited	7'h00
			16:0	R/W	CH1_IN_MIX_0	CH1_IN_MIX_0	17'h08000
0x31	3	CH1_IN_MIX_1	23:17	R	Reserved	Prohibited	7'h00
			16:0	R/W	CH1_IN_MIX_1	CH1_IN_MIX_1	17'h00000
0x32	3	CH2_IN_MIX_0	23:17	R	Reserved	Prohibited	7'h00
			16:0	R/W	CH2_IN_MIX_0	CH2_IN_MIX_0	17'h00000
0x33	3	CH2_IN_MIX_1	23:17	R	Reserved	Prohibited	7'h00
			16:0	R/W	CH2_IN_MIX_1	CH2_IN_MIX_1	17'h08000
0x34	3	DRC_AE	23:17	R	Reserved	Prohibited	7'h00
			16:0	R/W	DRC_AE	DRC energy estimator	17'h08000
0x35	3	DRC_1-AE	23:17	R	Reserved	Prohibited	7'h00
			16:0	R/W	DRC_1-AE	DRC energy estimator when releasing	17'h00000
0x36	3	DRC_AD	23:17	R	Reserved	Prohibited	7'h00
			16:0	R/W	DRC_AA	DRC attack time	17'h08000
0x37	3	DRC_AA	23:17	R	Reserved	Prohibited	7'h00
			16:0	R/W	DRC_AD	DRC release time	17'h08000
0x38	3	RMS_RPT_AE	23:17	R	Reserved	Prohibited	7'h00
			16:0	R/W	RMS_RPT_AE	Prohibited	17'h08000
0x3A	3	COMP_B0	23:17	R	Reserved		7'h00
			16:0	R/W	COMP_B0	Compensation filter coefficient B0	17'h08000
0x3B	3	COMP_B1	23:17	R	Reserved		7'h00
			16:0	R/W	COMP_B1	Compensation filter coefficient B1	17'h00000

ADDR	Byte	RegName	BITS	R/W	Name	Description	Default
0x3C	3	COMP_B2	23:17	R	Reserved		7'h00
			16:0	R/W	COMP_B2	Compensation filter coefficient B2	17'h00000
0x3D	3	COMP_B3	23:17	R	Reserved		7'h00
			16:0	R/W	COMP_B3	Compensation filter coefficient B3	17'h00000
0x3E	4	CH1_RMS_RPT	31:0	R	CH1_RMS_RPT[31:0]	Channel 1 final RMS output (Not available in 96k & 192kHz Sampling Rate)	32'h00000000
0x3F	4	CH2_RMS_RPT	31:0	R	CH2_RMS_RPT[31:0]	Channel 2 final RMS output (not available in 96k & 192kHz Sampling Rate)	32'h00000000
0x40	1	SW_RESET	7	W	SF_RESET	Write 1 to trigger software reset Need to wait 10ms for reset completion	1'b0
			6:0	R	Reserved	Prohibited	7'b0000000
0x6C	1	UVP_OPT	7	R	D_VCORE_OK	Prohibited	1'b1
			6	R/W	D_EN_DVDD_UV	0: Disable (default) 1: Enable	1'b0
			5:4	R/W	D_UVP_DVDD_VTH [1:0]	Prohibited	2'b10
			3	R/W	D_UV_RAMP_DOWN	SPK UV protection behavior 0: HZ_PROT directly (default) 1: Power-off sequence	1'b0
			2:0	R/W	D_UVP_PVDD_SEL [2:0]	Select UVP level for PVDD power domain 3'b000: 6.15V (default) 3'b001: 7.7V 3'b010: 8.5V 3'b011: 9.5V 3'b100: 10.9V 3'b101: 12.7V 3'b110: 15.4V 3'b111: 19.8V	3'b000

ADDR	Byte	RegName	BITS	R/W	Name	Description	Default
0xA0	1	AUD_TDM	7:4	R	Reserved		4'b0000
			3	R/W	SCLK_EDGE_SEL	0: RX @BCK rising edge & TX @BCK falling edge (default) 1: RX @BCK falling edge & TX @BCK rising edge	1'b0
			2	R/W	DATAO_PD	Prohibited	1'b0
			1	R/W	TDM_OFFSET	TDM offset selection 0: Without offset 1: 1bit clock offset (default)	1'b1
			0	R/W	TDM_EN	0: TDM disable TDM application (default) 1: TDM enable	1'b0
0xA1	1	TDM_RX_L	7:6	R	Reserved		2'b00
			5:0	R/W	TDM_RX_LOC_L	TDM start receiving location select for left channel (reg*8 + offset) 000000: Start from 0 + offset (default) 000001: Start from 8 + offset ... 111100: Start from 480 + offset 111101: Start from 488 + offset 111110: Not available 111111: Not available	6'b000000
0xA2	1	TDM_RX_R	7:6	R	Reserved		2'b00
			5:0	R/W	TDM_RX_LOC_R	TDM start receiving location select for left channel (reg*8 + offset) 000000: Start from 0 + offset 000001: Start from 8 + offset 000011: Start from 24 + offset (default) ... 111100: Start from 480 + offset 111101: Start from 488 + offset 111110: Not available 111111: Not available	6'b000011

ADDR	Byte	RegName	BITS	R/W	Name	Description	Default
0xA3	1	TDM_TX_L	7:6	R	Reserved		2'b00
			5:0	R/W	TDM_TX_LOC_L	TDM start transmitting location select for left channel (reg*8 + offset) 000000: Start from 0 + offset (default) 000001: Start from 8 + offset ... 111100: Start from 480 + offset 111101: Start from 488 + offset 111110: Not available 111111: Not available	6'b000000
0xA4	1	TDM_TX_R	7:6	R	Reserved		2'b00
			5:0	R/W	TDM_TX_LOC_R	TDM start transmitting location select for right channel (reg*8 + offset) 000000: Start from 0 + offset 000001: Start from 8 + offset 000011: Start from 24 + offset (default) ... 111100: Start from 480 + offset 111101: Start from 488 + offset 111110: Not available 111111: Not available	6'b000011

Outline Dimension

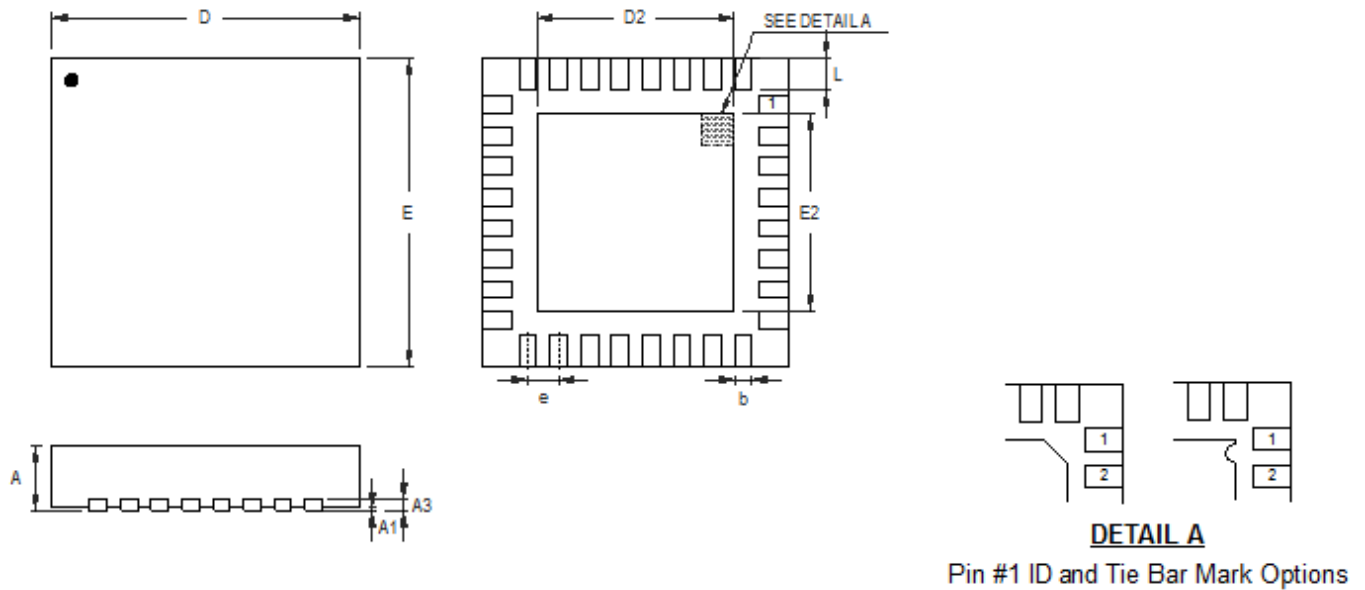

Note : The configuration of the Pin #1 identifier is optional, but must be located within the zone indicated.

Symbol	Dimensions In Millimeters		Dimensions In Inches	
	Min	Max	Min	Max
A	0.800	1.000	0.031	0.039
A1	0.000	0.050	0.000	0.002
A3	0.175	0.250	0.007	0.010
b	0.180	0.300	0.007	0.012
D	4.950	5.050	0.195	0.199
D2	3.400	3.750	0.134	0.148
E	4.950	5.050	0.195	0.199
E2	3.400	3.750	0.134	0.148
e	0.500		0.020	
L	0.350	0.450	0.014	0.018

V-Type 32L QFN 5x5 Package

Footprint Information

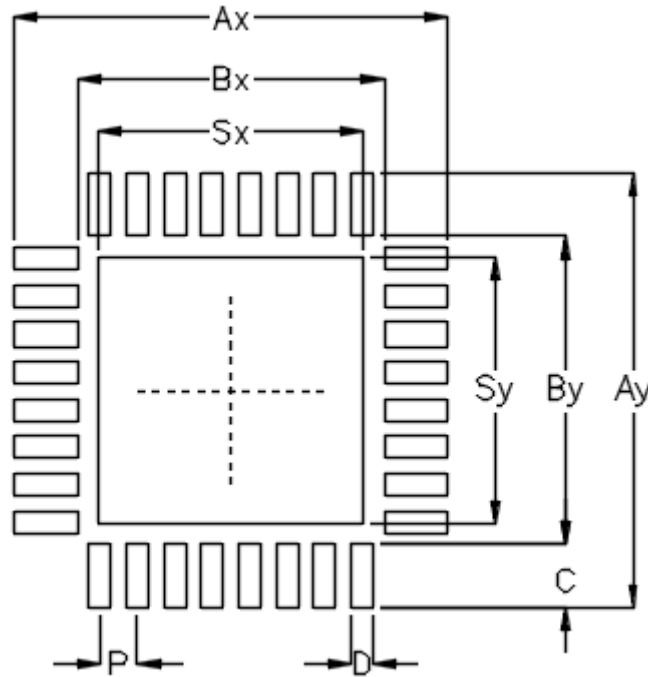

Package	Number of Pin	Footprint Dimension (mm)									Tolerance
		P	Ax	Ay	Bx	By	C	D	Sx	Sy	
V/W/U/XQFN5*5-32	32	0.50	5.80	5.80	4.10	4.10	0.85	0.30	3.55	3.55	±0.05

Packing Information

Tape and Reel Data

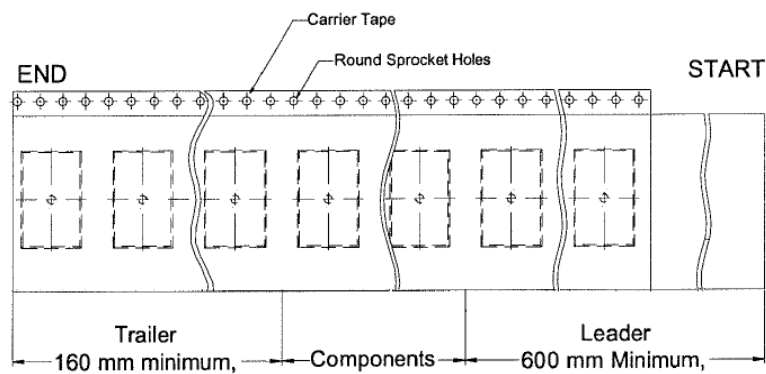
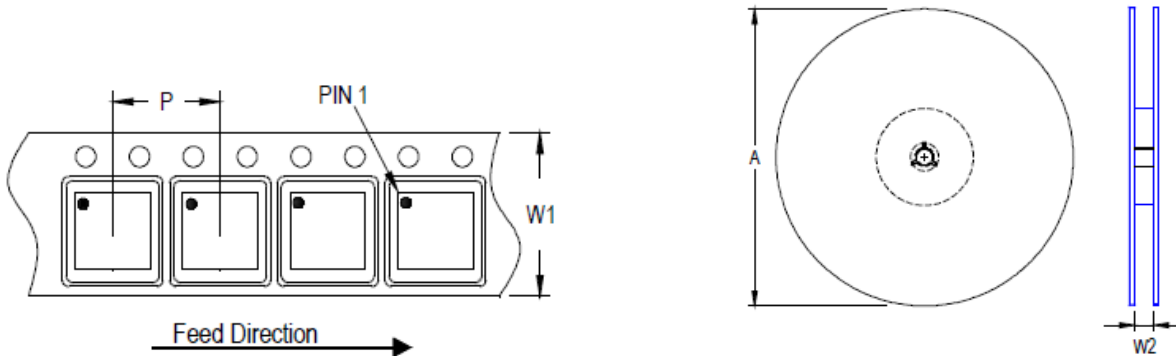

Package Type	Tape Size (W1) (mm)	Pocket Pitch (P) (mm)	Reel Size (A)		Units per Reel	Trailer (mm)	Leader (mm)	Reel Width (W2) Min./Max. (mm)
			(mm)	(in)				
QFN/DFN 5x5	12	8	180	7	1,500	160	600	12.4/14.4

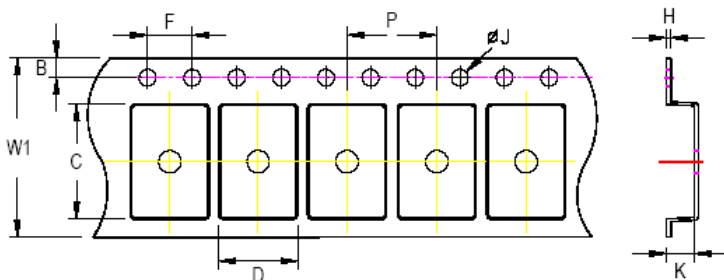







C, D and K are determined by component size.

The clearance between the components and

Tape Size	W1		P		B		F		ØJ		H
	Max.	Min.	Max.	Min.	Max.	Min.	Max.	Min.	Max.	Max.	
12mm	12.3mm	7.9mm	8.1mm	1.65mm	1.85mm	3.9mm	4.1mm	1.5mm	1.6mm	0.6mm	

Tape and Reel Packing

Step	Photo/Description	Step	Photo/Description
1	 <p>Reel 7"</p>	4	 <p>3 reels per inner box Box A</p>
2	 <p>HIC & Desiccant (1 Unit) inside</p>	5	 <p>12 inner boxes per outer box</p>
3	 <p>Caution label is on backside of Al bag</p>	6	 <p>Outer box Carton A</p>

Package	Container		Reel				Box				Carton			
	Size	Units	Item	Size(cm)	Reels	Units	Item	Size(cm)	Boxes	Unit				
QFN/DFN 5x5	7"	1,500	Box A	18.3*18.3*8.0	3	4,500	Carton A	38.3*27.2*38.3	12	54,000				
			Box E	18.6*18.6*3.5	1	1,500	For Combined or Un-full Reel.							

Packing Material Anti-ESD Property

Surface Resistance	Aluminum Bag	Reel	Cover tape	Carrier tape	Tube	Protection Band
Ω/cm^2	$10^4 \sim 10^{11}$	$10^4 \sim 10^{11}$	$10^4 \sim 10^{11}$	$10^4 \sim 10^{11}$	$10^4 \sim 10^{11}$	$10^4 \sim 10^{11}$

Richtek Technology Corporation

14F, No. 8, Tai Yuen 1st Street, Chupei City

Hsinchu, Taiwan, R.O.C.

Tel: (8863)5526789

RICHTEK

Richtek products are sold by description only. Richtek reserves the right to change the circuitry and/or specifications without notice at any time. Customers should obtain the latest relevant information and data sheets before placing orders and should verify that such information is current and complete. Richtek cannot assume responsibility for use of any circuitry other than circuitry entirely embodied in a Richtek product. Information furnished by Richtek is believed to be accurate and reliable. However, no responsibility is assumed by Richtek or its subsidiaries for its use; nor for any infringements of patents or other rights of third parties which may result from its use. No license is granted by implication or otherwise under any patent or patent rights of Richtek or its subsidiaries.

Copyright © 2022 Richtek Technology Corporation. All rights reserved. **RICHTEK** is a registered trademark of Richtek Technology Corporation.

Datasheet Revision History

Version	Date	Description	Item
00	2022/12/13	Final	Features on P1 Electrical Characteristics on P7